

1985

Model for horizontal tube settlers

Ahmed Ashry Fadel
Iowa State University

Follow this and additional works at: <https://lib.dr.iastate.edu/rtd>

 Part of the [Civil Engineering Commons](#)

Recommended Citation

Fadel, Ahmed Ashry, "Model for horizontal tube settlers " (1985). *Retrospective Theses and Dissertations*. 12059.
<https://lib.dr.iastate.edu/rtd/12059>

This Dissertation is brought to you for free and open access by the Iowa State University Capstones, Theses and Dissertations at Iowa State University Digital Repository. It has been accepted for inclusion in Retrospective Theses and Dissertations by an authorized administrator of Iowa State University Digital Repository. For more information, please contact digirep@iastate.edu.

INFORMATION TO USERS

This reproduction was made from a copy of a document sent to us for microfilming. While the most advanced technology has been used to photograph and reproduce this document, the quality of the reproduction is heavily dependent upon the quality of the material submitted.

The following explanation of techniques is provided to help clarify markings or notations which may appear on this reproduction.

1. The sign or "target" for pages apparently lacking from the document photographed is "Missing Page(s)". If it was possible to obtain the missing page(s) or section, they are spliced into the film along with adjacent pages. This may have necessitated cutting through an image and duplicating adjacent pages to assure complete continuity.
2. When an image on the film is obliterated with a round black mark, it is an indication of either blurred copy because of movement during exposure, duplicate copy, or copyrighted materials that should not have been filmed. For blurred pages, a good image of the page can be found in the adjacent frame. If copyrighted materials were deleted, a target note will appear listing the pages in the adjacent frame.
3. When a map, drawing or chart, etc., is part of the material being photographed, a definite method of "sectioning" the material has been followed. It is customary to begin filming at the upper left hand corner of a large sheet and to continue from left to right in equal sections with small overlaps. If necessary, sectioning is continued again—beginning below the first row and continuing on until complete.
4. For illustrations that cannot be satisfactorily reproduced by xerographic means, photographic prints can be purchased at additional cost and inserted into your xerographic copy. These prints are available upon request from the Dissertations Customer Services Department.
5. Some pages in any document may have indistinct print. In all cases the best available copy has been filmed.

**University
Microfilms
International**

300 N. Zeeb Road
Ann Arbor, MI 48106

8524649

Fadel, Ahmed Ashry

MODEL FOR HORIZONTAL TUBE SETTLERS

Iowa State University

Ph.D. 1985

University
Microfilms
International 300 N. Zeeb Road, Ann Arbor, MI 48106

PLEASE NOTE:

In all cases this material has been filmed in the best possible way from the available copy. Problems encountered with this document have been identified here with a check mark .

1. Glossy photographs or pages _____
2. Colored illustrations, paper or print _____
3. Photographs with dark background
4. Illustrations are poor copy _____
5. Pages with black marks, not original copy _____
6. Print shows through as there is text on both sides of page _____
7. Indistinct, broken or small print on several pages
8. Print exceeds margin requirements _____
9. Tightly bound copy with print lost in spine _____
10. Computer printout pages with indistinct print _____
11. Page(s) _____ lacking when material received, and not available from school or author.
12. Page(s) _____ seem to be missing in numbering only as text follows.
13. Two pages numbered _____. Text follows.
14. Curling and wrinkled pages _____
15. Dissertation contains pages with print at a slant, filmed as received _____
16. Other _____

University
Microfilms
International

Model for horizontal tube settlers

by

Ahmed Ashry Fadel

A Dissertation Submitted to the
Graduate Faculty in Partial Fulfillment of the
Requirements for the Degree of
DOCTOR OF PHILOSOPHY

Department: Civil Engineering
Major: Sanitary Engineering

Approved :

Signature was redacted for privacy.

In Charge of ~~Major~~ Work

Signature was redacted for privacy.

For ~~the~~ Major Department

Signature was redacted for privacy.

For the ~~Graduate~~ College

Iowa State University
Ames, Iowa

1985

TABLE OF CONTENTS

	Page
DEDICATION	xi
INTRODUCTION	1
REVIEW OF LITERATURE	3
Discrete Particle Settling	3
Flocculant Settling	6
Flow Regimes	7
Sedimentation Theory	8
Development of Tube Settlers	10
Tube Settlers	15
Design and Experimental Approaches	20
Culp et al.	20
Comments	25
Yao	29
Comments	38
Willis	40
Comments	42
Hernandez and Wright	43
Comments	45
Van Vliet	47
Comments	50
El-Baroudi and Fuller	50
Comments	54
Factors Affecting the Performance of Tube Settlers	54
Summary	56
UNSETTLED QUESTIONS	58
Actual Particle Trajectory	58
The Fadel model	63
Essentially-Horizontal vs Steeply-Inclined Tube	66
Inlet and Outlet Arrangement	68

THEORETICAL STUDY	72
Factors Affecting Tube Performance Using Fadel's Model	80
Differences Between the Fadel Model and Yao and Culp Models	87
Method of Using the Model	94
Essentially Horizontal Tubes	102
EXPERIMENTAL STUDY	113
Equipment and Materials	113
Equipment	113
Miscellaneous equipment	120
Materials	120
Suspension preparation	120
Disadvantages of the elutriation process	123
Experimental Procedure	124
RESULTS AND DISCUSSION	130
Part 1	130
Run #1. (2/18/85)	130
Run #2. (2/20/85)	132
Run #3. (2/22/85)	133
Run #4. (2/25/85)	133
Run #5. (2/27/85)	134
Run #6. (3/5/85-3/6/85)	135
General Comments, Runs #1 - #6	135
Run #7. (3/17/85)	136
Run #8. (3/19/85)	138
Run #9. (4/20/85)	139
Run #10. (4/5/85)	140
Run #11. (4/6/85)	141
Run #16. (4/11/85 to 4/13/85)	142
Run #21. (4/25/85)	144
General Comments on Runs #7, #11, #16, and #21	147
Part 2	148
Set #1	149

Set #2	151
Set #3	151
General Discussion on the Run Sets Conducted in Part 2	154
CONCLUSIONS	157
From the Theoretical Study	157
From the Experimental Study	158
RECOMMENDATIONS	160
REFERENCES	161
ACKNOWLEDGEMENTS	163
APPENDIX A. COMPUTER PROGRAMS	165
APPENDIX B. NUMERICAL SOLUTION OF FADEL'S MODEL	179

LIST OF TABLES

	Page
Table 1. Maximum flow rates in GPM/ft ² for steeply inclined tube ($\theta = 60^\circ$)	45
Table 2. Maximum flow rates in GPM/ft ² for essentially horizontal tubes ($\theta = 5^\circ$ M)	46
Table 3. Maximum flow rates in GP/ft ² for settling activated sludge mixed liquors ($\theta = 60^\circ$)	46
Table 4. Langhaar constants	59
Table 5. The effect of sludge accumulation on the required tube length for a 3" tube, settling velocity = 0.1 fpm, and degree of inclination = 5.0°	109
Table 6. The effect of sludge accumulation on the required tube length for the 4" tube, settling velocity = 0.1 fpm, and degree of inclination = 5.0°	109
Table 7. Results and computer-predicted results in Run #7	137
Table 8. A comparison between the different models using Run #7 data	138
Table 9. Results and computer-predicted results in Run #9	140
Table 10. Results and computer-predicted results in Run #10	141
Table 11. Results and computer-predicted results in Run #11	142
Table 12. Results and computer-predicted results in Run #16	144
Table 13. Results and computer-predicted results in Run #21	147
Table 14. Diameter of glass beads collected in the cups in Run set #1	149
Table 15. Diameter of glass beads collected in the cups in Run set #2	151
Table 16. Diameter of glass beads collected in the cups in Run set #3	154

LIST OF FIGURES

	Page
Figure 1. Drag coefficients of spheres, disks and cylinders	5
Figure 2. Settling column and settling curves for flocculant particles	5
Figure 3. Settling paths of discrete particles in an ideal basin	9
Figure 4. Different settling velocities in an ideal basin	9
Figure 5. Flocculated particle trajectory in an ideal basin	11
Figure 6. The effect of reducing the depth of a settling basin receiving flocculant particles	11
Figure 7. Tray in tank provides added floor area and increases solids removal	12
Figure 8. Possible tube cross-section designs	17
Figure 9. Basic configuration for tube settlers	17
Figure 10. Self-supporting beam module of steeply inclined tubes	18
Figure 11. Basic arrangement of horizontal tube alignment	18
Figure 12. Basic arrangement of inclined tube alignment	19
Figure 13. Downflow and upflow tilted plate separator	19
Figure 14. Normal and backwash operations of the Aqua-Reuse plant	21
Figure 15. Suggested arrangement for steeply inclined tube settlers by Willis	21
Figure 16. Straight line trajectory for the particles in tube settlers suggested by Culp et al.	23
Figure 17. Schematic diagram for the experimental test equipment used by Culp et al.	26
Figure 18. The effect of tube diameter, tube length, flow rate flocculation on the percent removal of turbidity	27

Figure 19.	The effect of the tube settler's degree of inclination on the percent removal of turbidity	28
Figure 20.	Coordinate system for the design model by Yao	31
Figure 21.	Relative settler length vs performance at $\theta = 0$	31
Figure 22.	Relative settler length vs performance at $\theta = 20^\circ, 40^\circ$	33
Figure 23.	Angle of inclination vs performance using Yao's approach	33
Figure 24.	Turbidity removal efficiency vs flow rate using Chen's data	36
Figure 25.	Inlet water turbidity vs efficiency using Chen's data	36
Figure 26.	Flow velocity vs efficiency using Chen's data	37
Figure 27.	Tube's relative length vs efficiency using Chen's data	37
Figure 28.	Performance of upflow vs downflow tube settlers after Yao	39
Figure 29.	Suggested single tube dimensions by Willis	39
Figure 30.	Schematic diagram of modules in primary clarifier for the experiment conducted by Van Vliet	49
Figure 31.	General performance of the clarifiers and the modules in Van Vliet experiment	49
Figure 32.	Sedimentation volume classification according to El-Baroudi and Fuller	52
Figure 33.	Schematic diagram for the model tank used in El-Baroudi and Fuller experiment	53
Figure 34.	Langhaar calculated velocity profiles	61
Figure 35.	Schematic diagram illustrates the particle path inside the tube using Fadel's model	64

Figure 36.	The upper surface of a steeply inclined tube bundle in a sedimentation tank.	70
Figure 37.	Suggested inlet-outlet arrangement for an essentially horizontal tube bundle in a sedimentation tank	71
Figure 38.	Particle trajectory for Example 1	81
Figure 39.	Particle trajectory for Example 2	82
Figure 40.	Particle trajectory for Example 3	83
Figure 41.	Particle trajectory for Example 4	84
Figure 42.	The effect of increasing tube diameter on the required tube length using Fadel's model	85
Figure 43.	The effect of the degree of inclination on the required tube length using Fadel's model	86
Figure 44.	The effect of increasing the flow velocity on the required tube length using Fadel's model	88
Figure 45.	The effect of increasing the particle settling velocity on the required tube length using Fadel's model	89
Figure 46.	The effect of temperature increase on the required tube length using Fadel's model	90
Figure 47.	Yao's shape factor equal the area under the parabolic velocity profile divided by the area under the uniform velocity profile	92
Figure 48.	The ratio of the required length by Yao to Culp's calculated length for 60° tubes	93
Figure 49.	The design chart for 2" diameter tubes	95
Figure 50.	The design chart for 3" diameter tubes	96
Figure 51.	The design chart for 4" diameter tubes	97
Figure 52.	The design chart for 5" diameter tubes	98

Figure 53.	The design chart for 6" diameter tubes	99
Figure 54.	"n" versus V_{av}/V_{sc} for 2" diameter tube	103
Figure 55.	"n" versus V_{av}/V_{sc} for 3" diameter tube	104
Figure 56.	"n" versus V_{av}/V_{sc} for 4" diameter tube	105
Figure 57.	"n" versus V_{av}/V_{sc} for 5" diameter tube	106
Figure 58.	"n" versus V_{av}/V_{sc} for 6" diameter tube	107
Figure 59.	Temperature effect on the "n" value	108
Figure 60.	Sludge accumulation effects on the required length for an essentially horizontal tube settler with a 3-inch diameter	111
Figure 61.	Sludge accumulation effects on the required length for essentially horizontal tube settler with a 4-inch diameter	112
Figure 62.	Schematic diagram for the experimental equipment	114
Figure 63.	Schematic program for the modified experimental equipment	116
Figure 64.	Schematic diagram for the three tubes used in the experiment	117
Figure 65.	Schematic diagram presents the elutriation process equipment used in the experiment	122
Figure 66.	Glass beads (bulk) used in the study	143
Figure 67.	Glass beads settled at the tube end, cup #1, Run #16	145
Figure 68.	Glass beads settled at the tube end, cup #3, Run #16	145
Figure 69.	Glass beads settled at the tube end, cup #5, Run #16	146
Figure 70.	Glass beads settled at the tube end, cup #7, Run #16	146
Figure 71.	The relationship between the depth reduction ratio (d_s/D) and particle diameter in Set #1	150

Figure 72. The relationship between the depth reduction ratio
(ds/D) and particle diameter in Set #2 152

Figure 73. The relationship between the depth reduction ratio
(ds/D) and particle diameter in Set #3 153

DEDICATION

To my wife, Rawia

INTRODUCTION

Separation of suspended solids from water is one of the oldest and most important problems in water and wastewater treatment. Sedimentation is the most widely used solids-removal process; approximately one-third of the total capital expense of an entire water treatment plant is devoted to its sedimentation tanks. Several attempts have been made to reduce sedimentation costs. These efforts range from attempts to increase sedimentation basin efficiency to elimination of sedimentation tanks altogether by using direct filtration processes instead. However, direct filtration processes are limited in application because they cannot be used to treat high turbidity water (> 200 NTU), nor are they applicable to waste water treatment.

Certain technical advances can reduce the size and cost of sedimentation units. One such advance is the use of high rate sedimentation, which usually reduces the liquid retention time in the settling device by reducing the distance necessary for the particles to settle in effecting their removal. These devices are normally tubes; parallel plates or other shapes are also considered as being tubes placed either horizontally or inclined at some angle to the horizontal.

Hazen (1904) suggested the idea of shallow-depth settling, Camp (1946) [4] explored it, and Hansen and Culp (1967) [5] demonstrated its practical application. Sedimentation-tanks incorporating tube with detention times of 15 minutes or less settlers can now achieve settling efficiencies comparable to or better than those normally obtained in conventional rectangular settling tanks generally having detention times

of two hours or more.

There are only two basic configurations of tube settlers, the "essentially horizontal" and the "steeply inclined." Essentially horizontal tubes have an angle of inclination, θ , less than 7.5° , while steeply inclined tubes have θ , as any angle up to 60° (θ is the angle to the horizontal). Several theoretical and experimental studies evaluating the performance of tube settlers under different conditions of flow rate, suspended solids constituents, tube lengths, tube diameters, and angle of inclination have been conducted. These studies indicate that the tube settler concept needs further exploration to provide operating information and to verify design criteria, especially in the "essentially horizontal" tubes.

REVIEW OF LITERATURE

Sedimentation may be defined as the separation of suspended particles by gravitational settling. When solids are heavier than water, four types of particle settling phenomena, or sedimentation, may occur. These types and their definitions follow:

- a. Discrete particle sedimentation: Particles settle individually, having no significant interaction with neighboring particles.
- b. Flocculant particle sedimentation: Particles flocculate or increase in mass and size during settling, thus they settle at a faster rate.
- c. Hindered sedimentation: Particles are affected by interparticle forces which hinder their settling, thus causing them to remain in fixed positions relative to each other and causing a liquid-solid interface to develop at the top of the settling mass.
- d. Compressive sedimentation: Particles are much more highly concentrated than in hindered settling, thus forming a higher particle concentration "zone" or structure in which further settling may occur only by compression of the structure.

Neither hindered nor compressive settling have any significant effects on the design of tube settlers. Therefore, the present study is limited to analysis of discrete and flocculant particle sedimentation.

Discrete Particle Settling

Newton's and Stoke's laws are used to analyze discrete particle settling. Newton's law allows for calculation of the particle's terminal

velocity by equating the gravitational forces on the particle to its frictional resistance, or drag. For spherical particles, the law yields:

$$V_c = \frac{4}{3} \frac{g(\rho_s - \rho)d}{C_D \rho} \quad (1)$$

where:

V_c = particle settling velocity

g = gravitational acceleration

ρ_s, ρ = the density of the particle and the density of water

d = diameter of the particle

C_D = drag coefficient.

The value of the drag coefficient, C_D , depends on whether the flow regime surrounding the particle is laminar or turbulent. Figure 1, after Metcalf and Eddy [17], shows the drag coefficients of three particle shapes plotted against the flow regimes represented by their Reynolds

numbers ($R_N = \frac{V_c d}{\nu}$). Stoke's law may be applied if the Reynolds number is

less than 0.3. The law is stated as:

$$V_c = \frac{g(\rho_s - \rho)d^2}{18\mu} \quad (2)$$

Sand is a good example of a discrete particle.

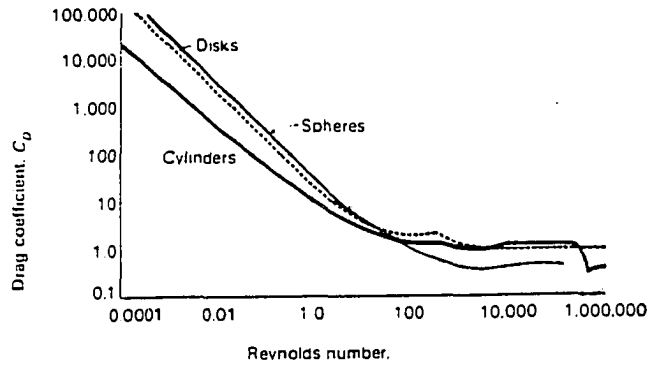

Figure 1. Drag coefficients of spheres, disks and cylinders

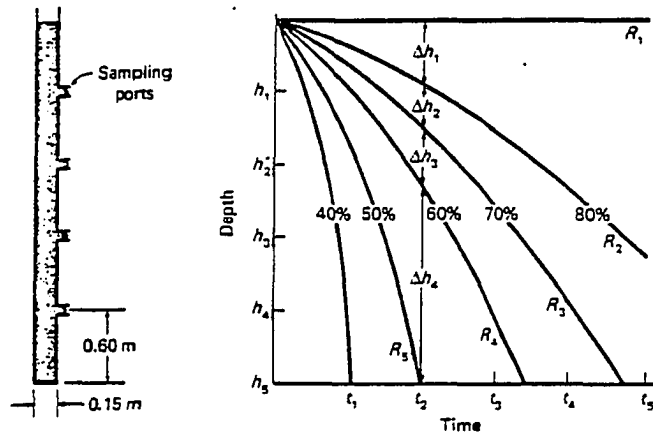

Figure 2. Settling column and settling curves for flocculant particles

Flocculant Settling

Particles may coalesce during sedimentation. When this occurs, particle mass increases and particles settle faster. Flocculation depends mainly on the individual particle's opportunity for contact with other individual particles. These opportunities vary with different sedimentation processes, flow rate conditions, basin depths, system velocity gradients, and particle concentrations and size ranges.

A settling column provides the simplest test method to determine this type of sedimentation requiring only a column having a 150 mm diameter and a height of 3 m for satisfactory performance. The test is easy to make and the results are readily available. Column sampling ports should be spaced at 0.6 m intervals, with samples collected at varying intervals of time.

Uniformity of temperature and particle size distribution from the top of the column to the bottom should be carefully monitored and controlled. After analysis, the percent of suspended solids removed may be computed and plotted against time and depth. The resulting plotted points are then drawn as curves showing the percent of suspended solids removal. A settling column and settling curves for flocculant particles are shown in Figure 2.

The percent of suspended solids removal may be calculated as:

$$\text{Percent Removal} = \sum_{i=1}^5 \frac{h_i}{h_5} \left[\frac{R_i + R_{i+1}}{2} \right] \quad (3)$$

However, the column test provides only an approximation of overall particle settling velocity and removal efficiency.

Flow Regimes

Flow regimes are usually classified according to their Reynolds number, RN, which expresses the relative magnitude of the accelerative (inertial) and viscous forces. In parametric form, this relationship is:

$$RN = \frac{VL}{\nu} \quad (4)$$

where:

RN = Reynolds number

V = a relative velocity between fluid and boundary;

L = a dimension (such as sphere diameter, depth of flow, etc.);

$\nu = \frac{\mu}{\rho}$, the kinematic viscosity of the fluid.

This relationship clearly indicates that the influence of viscosity is greater when Reynolds numbers are smaller, and less when Reynolds numbers are larger. The inclusion of viscosity allows for two vastly different flow conditions, laminar and turbulent. Laminar flow is characterized by fluid movement in parallel layers without crosscurrents, whereas turbulent flow is characterized by pulsatory crosscurrents. Laminar flow conditions exist only at low Reynolds numbers so, as the Reynolds number increases, a stage eventually must be reached at which the flow becomes unstable (or turbulent); disturbances of a particular magnitude will then result.

Reynolds number for laminar flow conditions occur within a given range of low numbers ($RN < 2100$) and turbulent conditions occur within a higher range ($RN > 4000$). Between these values, either laminar or turbulent flow may occur (depending on whether the starting flow

conditions were laminar or turbulent). Thus, laminar flow conditions may exist up to $RN = 4000$, if the flow velocity increases gradually. This region has been termed the "transition zone."

Sedimentation Theory

Camp (1946) [4] defined an "ideal basin" as a settling tank in which settling takes place exactly as it would in a quiescent settling column of equal depth. Such an ideal basin would be rectangular with continuous flow, and would have the following characteristics:

(1) Horizontal flow, with uniform velocity in all parts of the settling zone.

(2) Uniform vertical distribution of suspended particles at the inlet zone.

(3) Removal of particles from suspension when they reached the bottom of the settling zone.

The settling paths of discrete particles in the settling zone of an ideal basin are illustrated in Figure 3, after Camp. A discrete particle will have two velocity components in the ideal basin, V_s and V . The downward settling velocity of the particle itself is represented by V_s , and the velocity of the moving fluid by V , making the particle's actual velocity the vector sum of these two components. Both the trajectory of a discrete particle having a settling velocity slow enough to be barely sufficient for particle removal and the different velocity components in the basin are illustrated in Figure 4. This resultant settling velocity may be termed the "critical settling velocity," or V_{sc} . All particles having a settling velocity greater than or equal to

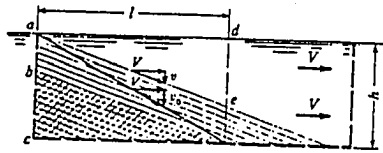

Figure 3. Settling paths of discrete particles in an ideal basin [2]

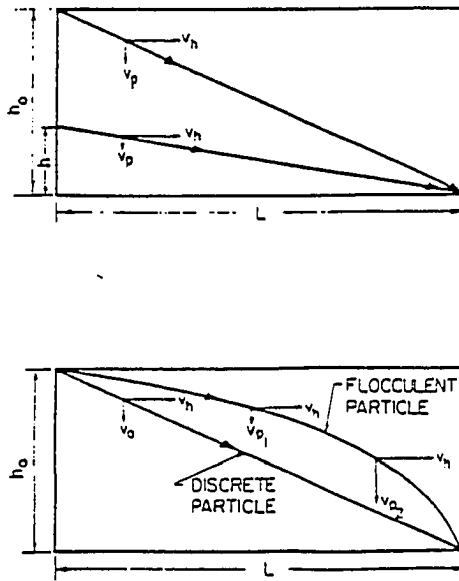

Figure 4. Different settling velocities in an ideal basin

V_{sc} will reach the bottom of the tank and be removed; however, particles with settling velocities lower than V_{sc} will not reach the bottom of the tank unless they enter some distance below the top. Different settling velocities in an ideal basin are illustrated in Figure 4.

Dick (1969) [7] suggested a trajectory for a flocculant particle illustrated under ideal basin condition, in Figure 5. By definition, the flocculant particle must increase in mass due to agglomeration with other particles along its settling path, thus becoming heavier and larger with time and gaining more drag through the increased area. Therefore, it settles faster as it progresses through the tank. Figure 6, after Dick [7], shows the effect of reducing the depth of a settling basin receiving flocculant particles. The flocculant particles will not be removed.

Development of Tube Settlers

The development of tube settlers resulted from experimentation in settling tanks and basins. Camp (1953) [3] reported a 1952 modification to sedimentation basins in Cambridge, Massachusetts, in which trays were added, increasing the settling capacity to nearly three times that available in the old basins, Figure 7, he concluded that adding trays increased the surface area, and significantly decreased surface loading. Addition of trays also proved that sedimentation is independent of depth: between two sequential trays, each space worked as a separate sedimentation tank having the same surface area and surface loading as the tank before modification.

Fischerstrom [10], a later researcher, thought tray spacing was limited by the solids removal problem. Suggesting that the space between

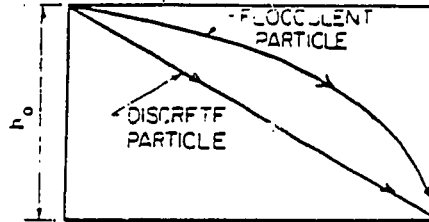

Figure 5. Flocculated particle trajectory in an ideal basin [7]

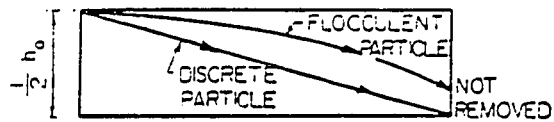

Figure 6. The effect of reducing the depth of a settling basin receiving flocculant particles [7]

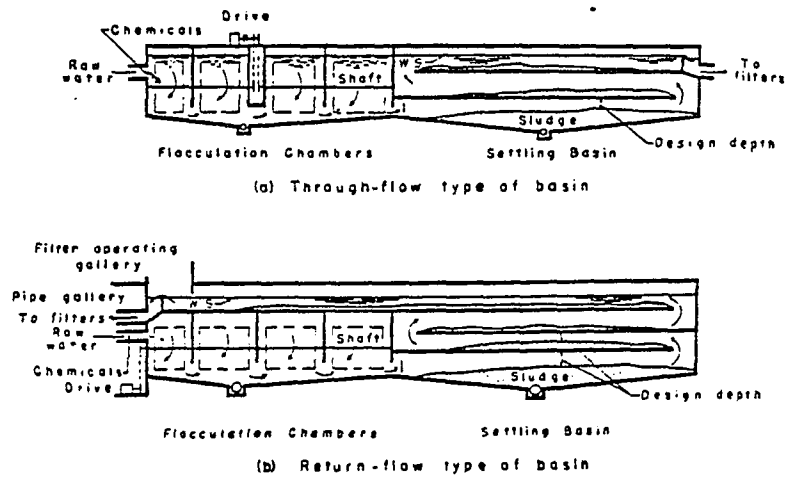

Figure 7. Tray in tank provides added floor area and increases solids removal [3]

two trays be large enough to allow for sludge removal equipment, Fischerstrom reported that one should also add vertical baffles to reduce the R_N values. Both vertical baffles and horizontal trays increase the wetted perimeter, reduce the hydraulic radius, and accordingly, reduce the Reynolds number.

Joining these three factors (wetted perimeter, surface loading, or overflow rate and tank depth) to problems experienced in adding trays to shallow sedimentation tanks, Culp and Hansen [5] proposed the idea of tube settlers. When stacked in layers, tube settlers increase the sedimentation surface area by a number equal to the number of layers stacked, so that a stack of three tube settlers has three times the surface area of one, a stack of six has six times the surface area, and so on. The wetted perimeter also increases by an equivalent number over that of an ordinary settling basin having the same volume as that of the tubes. According to the above discussion, there are two phenomena that have contributed to the development of tube settlers.

Phenomenon 1: The settling of discrete particles is independent of the sedimentation tank depth. This can be proved as follows:

The velocity of the settling particle in the direction of flow, V , is

$$V = \frac{Q}{dw} \quad (5)$$

where Q is the flow rate through the basin, w is the width of the basin, and d is the depth of the basin. From similar triangles, one may derive

$$\frac{V_{sc}}{V} = \frac{d}{L}$$

where V_{sc} = particle settling velocity due to gravity, and
 $\frac{Q}{A}$ = velocity is the velocity of the smallest completely
 removed particle.

L = the length of the basin.

Accordingly,

$$V_{sc} = \frac{Vd}{L} = \frac{Qd}{dwL} = \frac{Q}{A} \quad (6)$$

where $A = wL$ = basin surface area.

Equation (6), $\frac{Q}{A}$ is called the "overflow rate," "surface settling rate," "surface loading." The surface loading is the basic design parameter in water clarification. Equation (6) implies that removal of free settling particles in an ideal settling basin depends on surface loading but not on volume, indicating that removal is entirely independent of the basin's depth.

Phenomenon 2: Laminar flow conditions yield better settling performance. This flow regime depends on the boundary conditions of the settling tank. Culp et al. [6] reported that most tanks at that time were operated at RN values of 1000 to 25,000. Fischerstrom [10] reported that sedimentation tanks should be operated in the laminar region if good sedimentation were to be obtained. The R value for laminar flow in wide,

open-channel flows has been found to be 500 where $RN = \frac{d'V}{\nu}$, and d' is the depth of the channel. Since the laminar region for wide channels is considered to be less than 500, Culp et al. data indicate that most tanks were being operated at flow rates several times the optimum sedimentation rate.

Good, economical sedimentation processes will be obtained by incorporating these phenomena in the design operations of sedimentation facilities.

Tube Settlers

A typical tube settler consists of a modular unit of thin-walled tubes having a small cross-sectional area. The units are relatively lightweight, since they are usually made of PVC plastic or similar materials. The cross-sections of the individual tubes may be circular, square, rectangular, or even hexagonal. Six possible tube designs are illustrated in Figure 8. Tube dimensions range from 2 to 3 inches wide, with practical lengths ranging from 2 to 8 feet.

The two basic tube configurations shown in Figure 9 were described by Culp et al. [6] as:

- (a) Essentially horizontal, in which tubes are inclined to the horizontal at an angle ranging from 0 to 7.5°; and
- (b) Steeply inclined, in which the degree of inclination to the horizontal is approximately 60°.

Culp et al. also showed that tube settlers in the steeply inclined position can be made into a "self-supporting beam" by alternating the direction of tube inclinations within the module. Such alteration

prevents short circuiting of flow by limiting current velocity. Short-circuiting of flow may result if all tubes are inclined in the same direction. An example of a self-supporting beam module is shown in Figure 10.

Yao [28] reported that tube settlers can be classified according to the direction of flow as upflow and downflow high-rate settlers. He reported that an angle of inclination of 30° may be used for the downflow tube settlers, and that this angle of inclination is sufficient to obtain self-cleaning action.

Several methods of arrangement have been proposed, and put into practice, for tube settler location in sedimentation basins. Two treatment units manufactured by Neptune MicroFloc, Inc. (USA) are shown in Figures 11 and 12 (after Culp [6]). One uses a nest of horizontal tube settlers in which the tubes are backflushed by the backwashing water of the filters. The unit must be dewatered before backflushing if this treatment method is to be used. The other treatment method uses a steeply-inclined, self-cleaning tube having an inclination of 60° to the horizontal.

Another high rate settler configuration is the "Tilted Plate Separator," reported by Yao [28]. Used fairly widely in Europe and listed by Chemical Engineering magazine as being among the top ten most popular new equipment items introduced in the year ending July, 1969, the device consists of closely spaced inclined parallel plates. A downflow and upflow Tilted Plate Separator is illustrated in Figure 13. Yao mentioned that an upflow parallel plate separator unit was successfully used in an extended aeration system called Aqua-Reuse; the plant had a

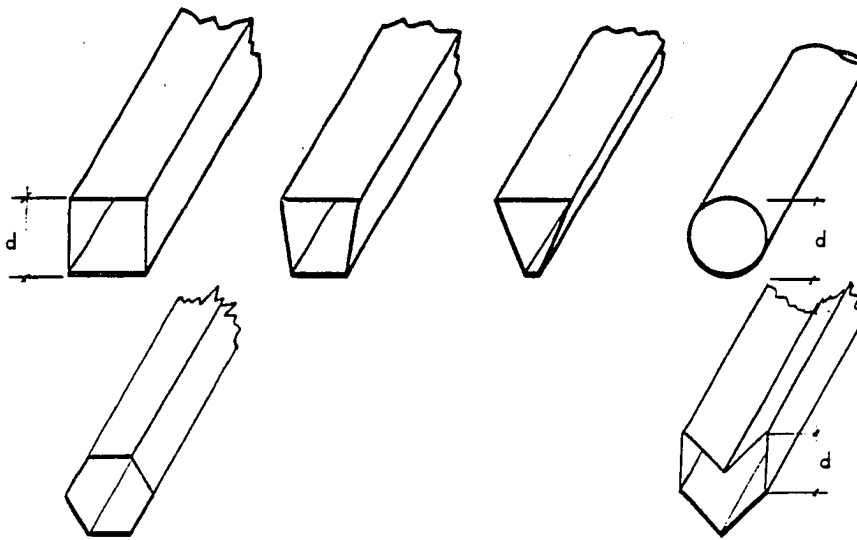

Figure 8. Possible tube cross-section designs

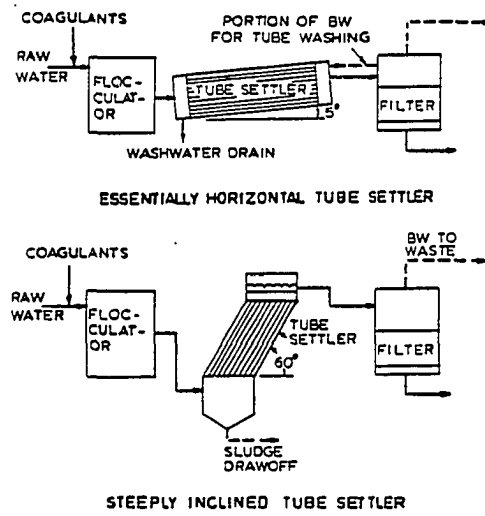

Figure 9. Basic configuration for tube settlers

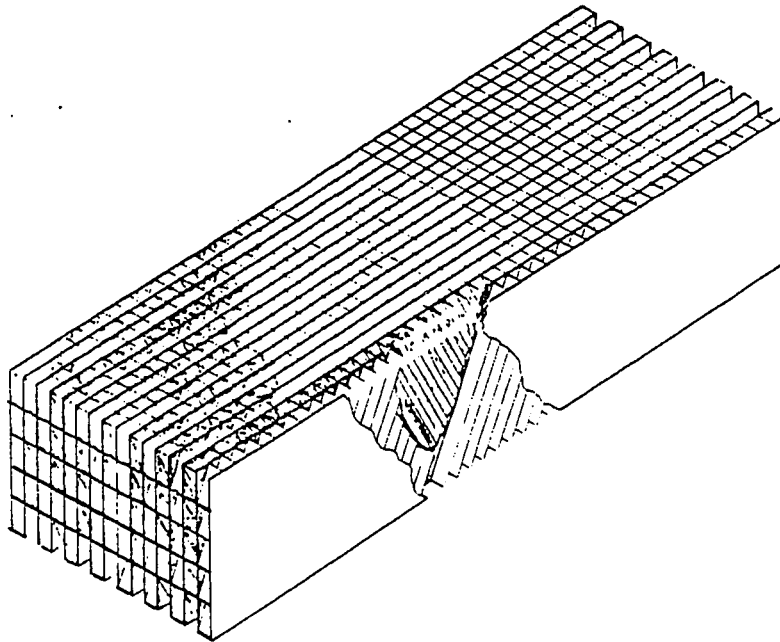

Figure 10. Self-supporting beam module of steeply inclined tubes

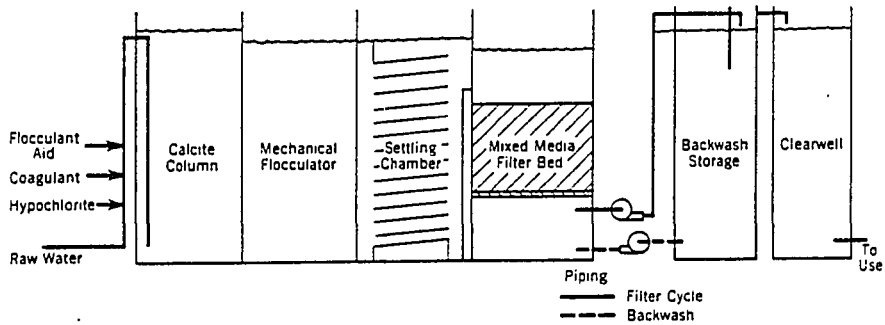

Figure 11. Basic arrangement of horizontal tube alignment [6]

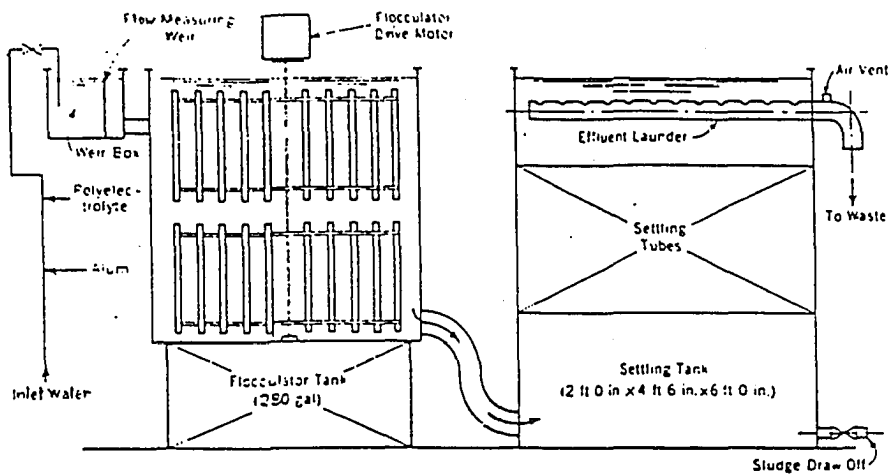

Figure 12. Basic arrangement of inclined tube alignment [6]

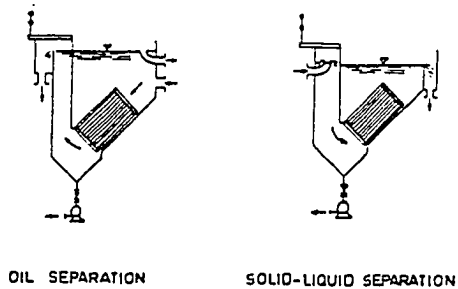

Figure 13. Downflow and upflow tilted plate separator [28]

backwash arrangement to keep the unit clean. The plates in this unit are 0.375 inch apart and inclined at 60° to the horizontal. Suspended solids removal efficiency was found to be 95%. Backwashing water was supplied by an air lift pump operated by a timing device and using the same air source as aeration. Both normal operation and backwashing for two different Aqua-Reuse Plant configurations are shown in Figure 14.

Willis [25] suggested the arrangement for steeply inclined tube settlers shown in Figure 15. Proposing a rectangular sedimentation tank with steeply inclined nested tube settlers, he recommended that distribution headers similar to the underdrain of rapid sand filters be placed below the inlet face to the tube bundle. On top of the tube bundle, Willis suggested another submerged discharge bundle, or launders, with adjustable weirs to control flow distribution through the tubes. Several arrangements for tube settlers in industrial and waste water treatment plants can be found in the literature.

Design and Experimental Approaches

Unfortunately, little has been done to explore tube settler concepts. Out of eleven published papers, only five have design approaches; of these five, only three include data from experimental investigations. These papers are summarized below. Comments follow each summary.

Culp et al.

Culp et al. [5,6] considered a straight line trajectory for the particles in the tube settlers shown in Figure 16. If one knows V_0 (average flow velocity in the tube) and the minimum settling velocity

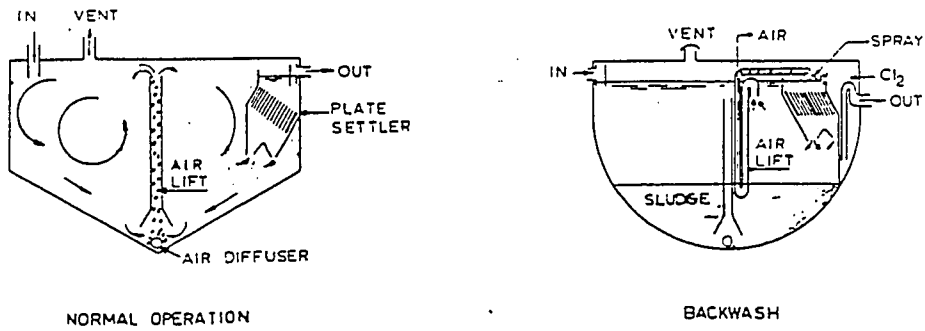

Figure 14. Normal and backwash operations of the Aqua-Reuse plant [28]

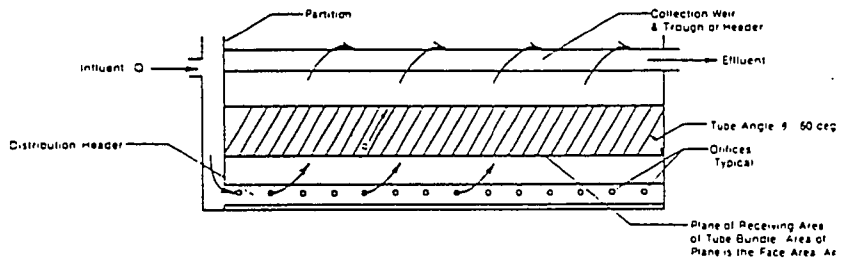

Figure 15. Suggested arrangement for steeply inclined tube settlers by Willis [25]

for the particles to be removed, V_{sc} , one can then assume a reasonable tube diameter of 2 to 8 inches; the required length is then obtained by triangular similarity, according to the equation below.

$$L_s = \frac{d(V_0 - V_{sc} \sin \theta)}{V_{sc} \cos \theta} \quad (7)$$

where: L_s = the required settling length

d = tube diameter

θ = degree of inclination of the tube from the horizontal

V_0 = the average velocity across the tube.

Culp et al. stated that at a certain V_0 and V_{sc} , where $V_0 > V_{sc}$, the required length of the settling surface decreases as the angle increases from zero to a certain θ ; this θ value depends on the ratio of V_0 to V_{sc} , e.g., for $V_0 = 2.5 V_{sc}$, θ will be between 25-30 degrees. After this angle is reached, the required length increases. Accordingly, as the angle of inclination (θ) is increased to 90°, the length required approaches infinity.

Culp et al. conducted two sets of experiments on circular high-rate settlers. In the first set, four tubes having diameters of 1/2 in., 1 in., 2 in., and 4 in. were used. Three different tube lengths of 2 ft., 4 ft., and 8 ft., based on the tube cross-sectional area, were used. Flow rates of 2, 5, and 8 GPM/ft² were used. The raw water turbidities used were 150 or 450 Jackson units. Some of the runs were conducted using a polyelectrolyte dose of 0.2 and 0.5 mg/l. The second set of experiments was designed to check the effects of the degree of inclination on the tube's performance by testing five tubes each 4 feet

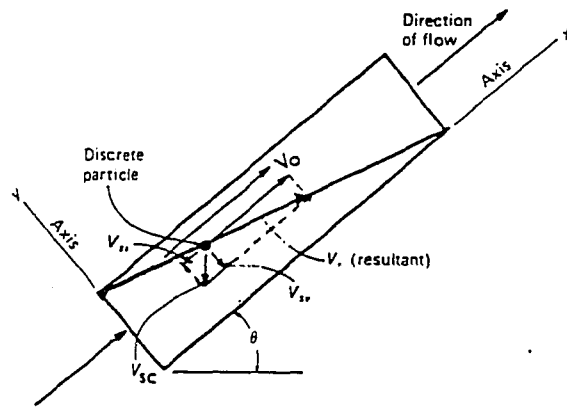

Figure 16. Straight line trajectory for the particles in tube settlers suggested by Culp et al. [6]

long and having a 1 inch diameter. The five tubes were re-tested individually and inclined at angles of 0, 5, 20, 40, and 90°. Figure 17 illustrates a schematic diagram of the equipment used in his two experiments.

From the first series of experiments, Culp et al. concluded:

(1) Smaller tube diameters enhanced effluent turbidity reduction at the same flow rate and the same inlet turbidity. Figure 18 shows the effects of tube diameter on the turbidity percent removal at different conditions of flow rate and tube length.

(2) Longer tubes performed better, indicating that smaller diameter long tubes would perform better than large, short ones. Figure 18 shows both effects on the removal efficiency of the tubes.

(3) Lower flow rates are recommended in order to increase the settling efficiency; Figure 18 indicates that a low flow rate through a small, long tube yields the best performance.

(4) Polyelectrolyte coagulation ahead of the tube bundle significantly increased removal efficiency.

(5) Inclining the tubes slightly in the direction of flow permits sludge removal by gravity drainage and eliminates the need for mechanical sludge removal equipment.

(6) Horizontal tube settlers provide at least 24 hours of sludge storage.

In the second experiment, Culp et al. observed that:

(1) Tube performance decreases slightly when the degree of inclination increased from zero to 10 - 20 degrees.

(2) Increasing inclination from 10 - 20 degrees to 40 - 45

degrees increases efficiency. However, past 45 degrees, efficiency decreases again until it reaches its lowest value with the tubes inclined at 90 degrees.

Figure 19 illustrates Culp et al. observations; unfortunately, Culp et al. did not explain the difference between the two curves shown in this figure.

Comments

Culp et al. assumption that the particle's settling path would be a straight line was based erroneously on an assumed uniform flow velocity through the tube. In fact, for laminar flow the tube's actual velocity profile varies from uniform flow at the entrance to a fully developed laminar velocity profile after a certain flow length. This variation increases the required length for particle settlement. Therefore, assuming a straight-line trajectory led Culp et al. to underestimate the required tube length.

Culp et al. experimental method was poor, in that he controlled the flow through the tubes by using a pinch clamp at the outlet end of each tube and measured turbidity using a light transmittance colorimeter. This is a poor turbidity measuring device; there were better devices available at the time.

Culp et al. mentioned the non-self-cleaning tubes had an advantage in that the build-up of solids in the tubes would cause a self-orificing of the flow leading to even distribution using the Neptune micro-floc unit. Equal flow distribution through the run is essential for successful operation. This implies that the inlet for the system

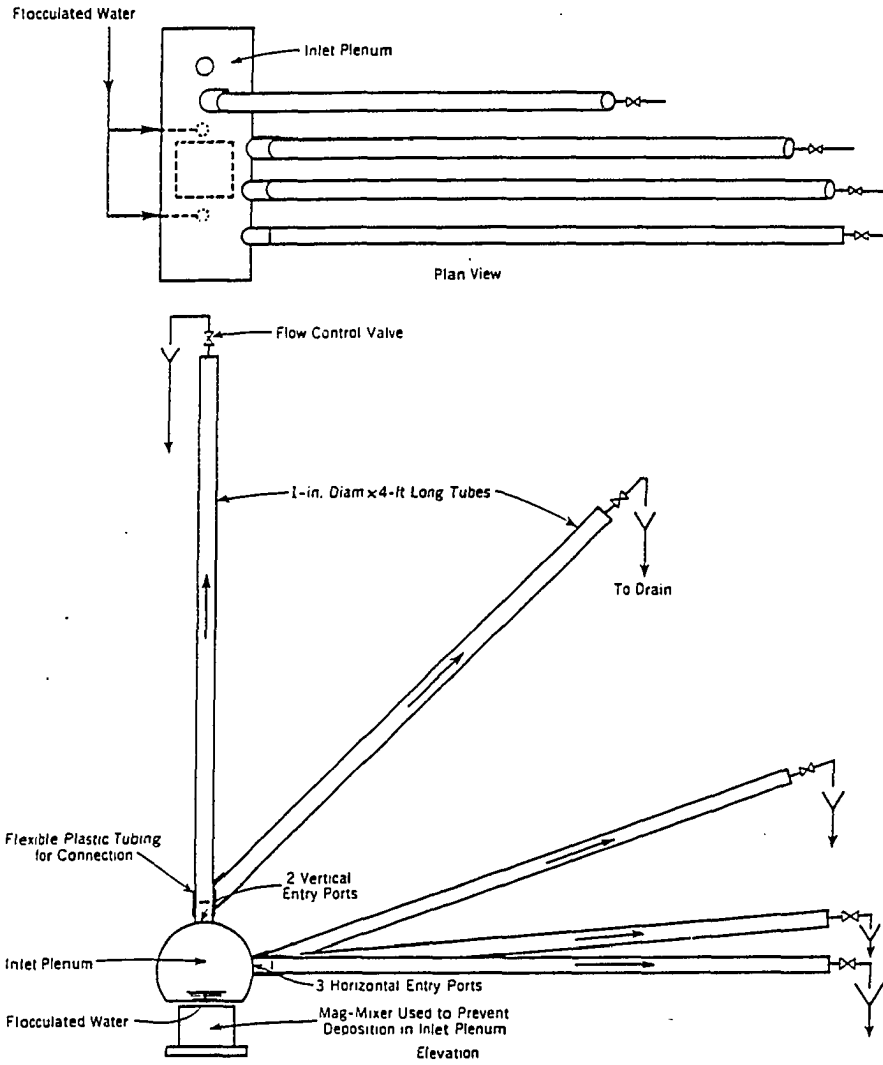
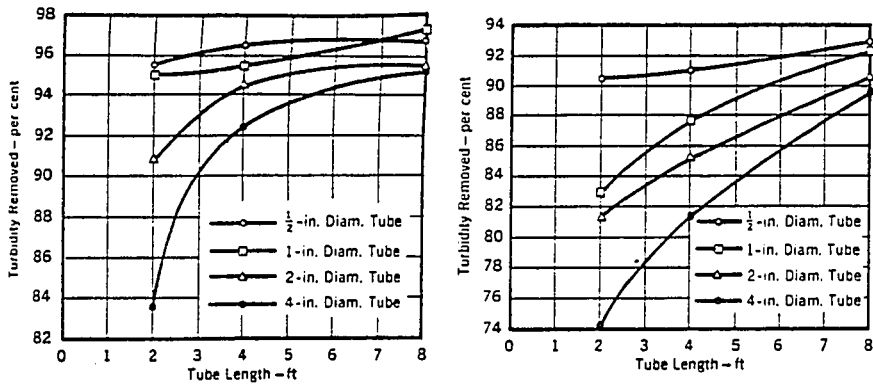

Figure 17. Schematic diagram for the experimental test equipment used by Culp et al. [6]



Flow rate was 2 gpm/sq ft; alum dosage, 100 mg/l; flocculation time, 20 min; and average influent turbidity, 450 Jackson units. There was no polyelectrolyte dosage.

Flow rate was 5 gpm/sq ft; alum dosage 100 mg/l; polyelectrolyte dosage, 0.5 mg/l; flocculation time 20 min; and average influent turbidity, 450 Jackson units.

Figure 18. The effect of tube diameter, tube length, flow rate and flocculation on the percent removal of turbidity [6]

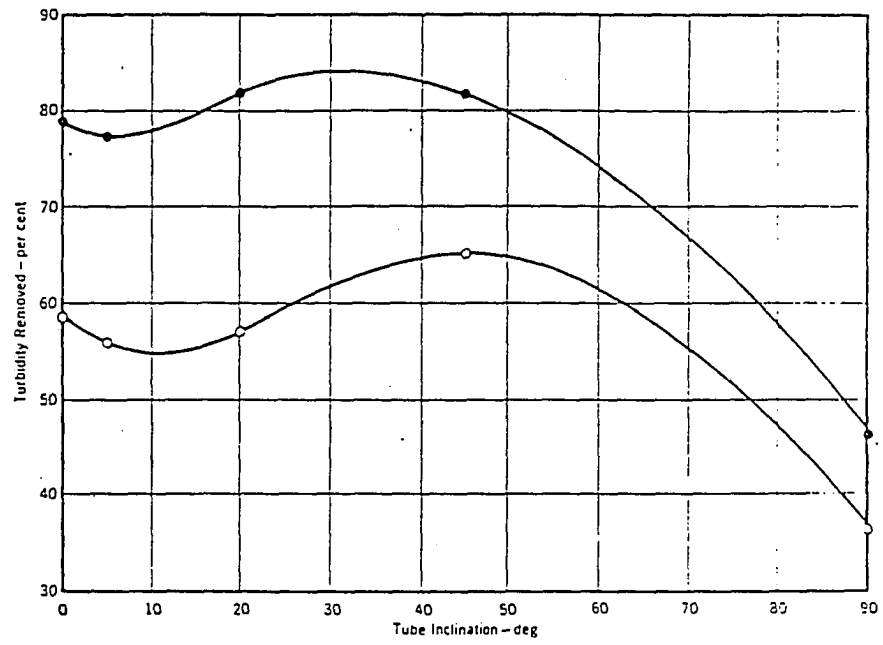

Figure 19. The effect of the tube settler's degree of inclination on the percent removal of turbidity [6].

(Figure 11) was improperly designed.

Yao

Yao [27] assumed that flow conditions in a high rate settler were laminar and particles were discrete. Essentially, Yao separated the velocity components in a manner similar to Culp et al. (Figure 20). The velocity u is the local fluid velocity. Using the angle of inclination, θ , and the following velocity components in the x and y directions, Yao defined:

$$u_x = u - V_{sc} \sin \theta \quad (3)$$

$$u_y = -V_{sc} \cos \theta \quad (9)$$

By definition, $u_x = dx/dt$ and $u_y = dy/dt$. Dividing u_x and u_y leads to a trajectory equation resulting from the combined effects of fluid drag and gravitational settling, as follows:

$$\frac{dy}{dx} = -V_{sc} \cos \theta / u - V_{sc} \sin \theta \quad (10)$$

The integration of Equation (10) leads to the following equation:

$$u dy - V_{sc} y \sin \theta + V_{sc} x \cos \theta = c \quad (11)$$

Dividing all terms in Equation (11) by V_o , the average flow velocity (which is equal to the flow, Q , divided by the area normal to the tubes) and d (the depth of the flow normal to u) leads to the general equation for particle trajectories shown below:

$$u/V_0 dy - V_{sc} \underline{Y} \sin \theta + V_{sc}/V_0 X \sin \theta = c_1 \quad (12)$$

where:

c_1 = an adjusted integration constant

$\underline{Y} = y/d$, and

$X = x/d$

According to Camp's analysis of settling velocities in an ideal basin, particles following trajectory F_1 (Figure 20) have the lowest settling velocity; thus, they represent V_{sc} , the "critical settling velocity" used in the above derivation.

Evaluating different tube settler shapes by using the general equation for particle trajectories and the relationship between u and V_0 . Yao concluded that, for the limiting trajectory, F_1 , there are two boundary conditions which may be used to arrive at a design equation for each specific tube shape. These boundary conditions are as follows:

$$X = L \text{ at } \underline{Y} = 0 \text{ and } X = 0 \text{ at } \underline{Y} = 1.$$

L = the relative length.

= l/d (the length of the settler divided by the distance normal to the fluid velocity i.e., the tube diameter.)

The integration constant, c_1 , in Equation (12) evaluated by substituting the first boundary conditions into the trajectory equation was evaluated for the specific settler shape, as follows:

$$V_{sc}/V_0 (\sin \theta + L \cos \theta) = S_c \quad (13)$$

Yao found the value of S_c to be: $4/3$ for circular tube settlers, 1 for

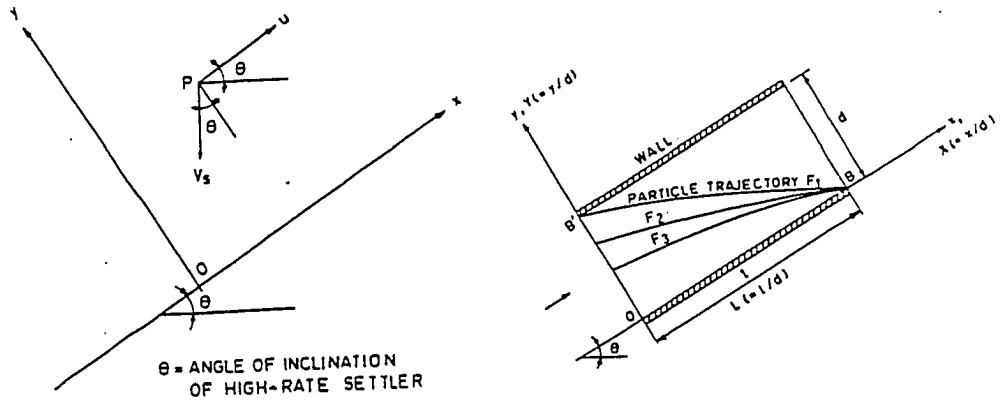

Figure 20. Coordinate system for the design model by Yao [27]

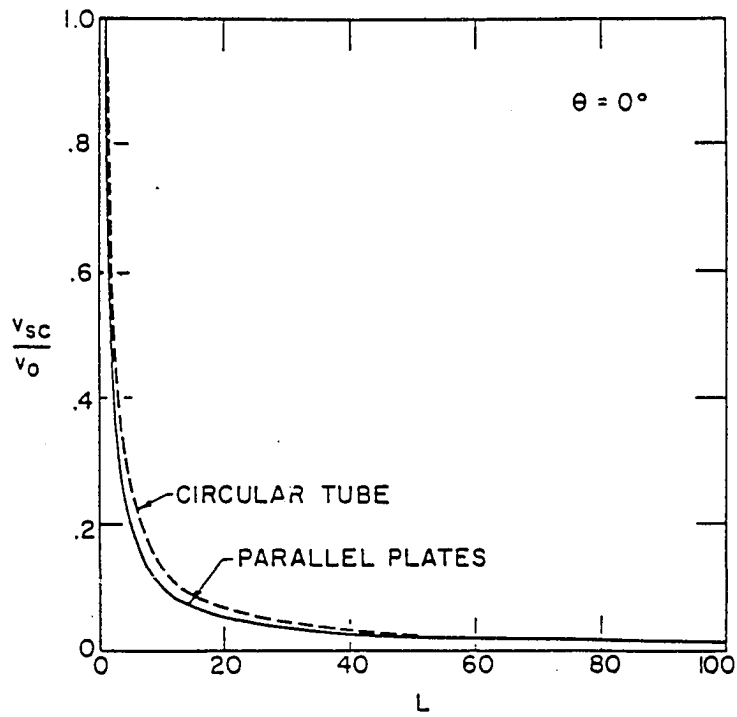

Figure 21. Relative settler length vs performance at $\theta = 0$ [27]

parallel plates, $11/8$ for square conduits, 1 for shallow open trays, and 1 for systems with uniform velocity distribution.

The relationship for the ratio (u/V_o) used in deriving the S_c values is a result of the fluid's viscosity. Viscosity introduces a resistance to motion, creating a non-linear velocity profile distribution. Evaluation of (u/V_o) for circular tubes in laminar flow results in a parabolic shape, described by the equation $8(y - y^2)$.

From the settling characteristics of the solid (V_{sc}), the settler shape (S_c), the angle of inclination (θ), the spacing or height of the settler (d), and the flow rate, one can determine the required tube length using Yao's Equation (13).

For a fixed V_o , Yao showed that the value of V_{sc} decreases as L increases (when L is relatively small). The rate of decrease in V_{sc} drops appreciably after L reaches 20 and becomes nearly flat after L reaches 40, as illustrated in Figure 21. The angle of inclination chosen for this graphical representation was $\theta = 0^\circ$. Since this angle of inclination is impractical, Yao presented another drawing, Figure 22, for $\theta = 20$ and 40° , in which he obtained the same pattern as that for $\theta = 0^\circ$. The curves flatten, after L reaches 40, so increasing L reduces the V_{sc} value very little; hence, L should be kept below 40 and probably closer to 20 for optimal economical design.

Yao found that the optimum angle for a minimum V_{sc} value to be:

$$\theta = \tan^{-1}(1/L) \quad (14)$$

For L equal to 20, the optimum inclination angle becomes $2^\circ 52'$.

Performance for various angles of inclination are shown in Figures (23);

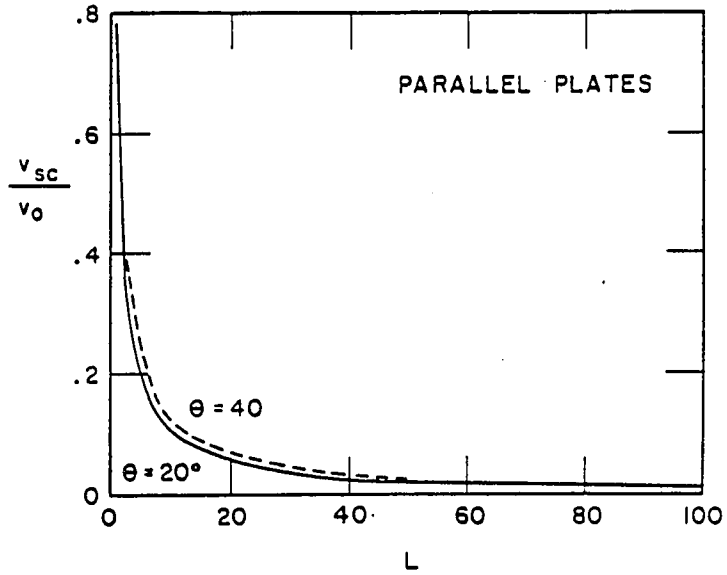

Figure 22. Relative settler length vs performance at $\theta = 20^\circ, 40^\circ$
[27]

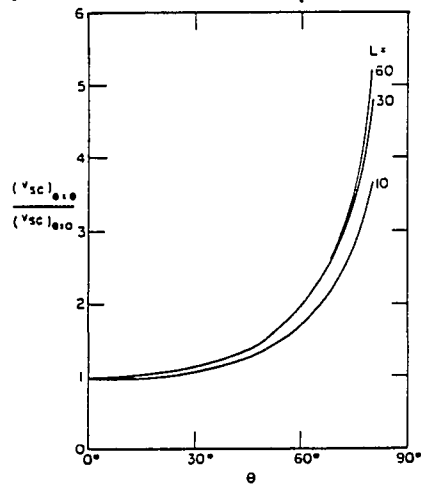

Figure 23. Angle of inclination vs performance using Yao's approach
[27]

note that performance decreases rapidly beyond a value of about 40°.

In the same study, Yao recommended that designers consider the entrance length required to establish a laminar flow and stated that for practical installations, the settlers will probably be connected to an inlet chamber having a relatively large sectional area. At the entrance to a settler, a transition region exists in which uniform flow gradually changes into fully developed laminar flow, due to the influence of the solid boundary and fluid viscosity. In circular tubes, the relative length, L' (relative length equal to the transition length divided by tube diameter), for this transition region may be estimated using Langahaar's equation:

$$L' = 0.058 \frac{v_o d}{v} \quad (15)$$

This length could be added to the design length of the tube settlers. If the required entrance length is longer than the design length, Yao stated that the total should be taken as twice the design length. It is noteworthy that this equation is based on the fact that the flow has a uniform velocity value at the entrance face of the tube.

Yao [28] later reviewed Chen's thesis data (National Taiwan University). Chen conducted an extensive experimental study of circular upflow high-rate settlers similar to those described by Culp et al. [6], using four tube sizes (0.5, 1, 2, and 3 inches), three tube lengths (2, 3, and 5 feet), and four flow velocities. Raw water was taken from an irrigation canal and a koalin suspension was added to adjust the suspended solids level to the desired level. Chen conducted three sets of runs, the first set of which used a constant angle of inclination of

60° at ten different raw water suspended solids concentrations, ranging from 15 mg/l to 90 mg/l. The second set held raw water suspended solids at a constant 50 mg/l, with six different angles of inclination: 0, 15, 30, 45, 60, and 75°. In the third set, Chen lowered his raw water solids level to 50 mg/l; other experimental conditions duplicated those of the second set. An average alum dose of 20 mg/l was used with flocculation; Reynolds numbers ranged from 15 to 370 and relative lengths ranged from 8 to 120.

Using a digital computer, to analyze Chen's data, Yao illustrated:

- (a) Turbidity removal efficiently decreased as the flow rate increased, Figure 24.
- (b) Higher raw water turbidities yielded better efficiency, Figure 25.
- (c) Better flocculation before settling and particle aggregation during settling could improve efficiency.
- (d) Higher flow velocities yielded lower removal efficiency, Figure 26.
- (e) There was no definite trend indicating that settler efficiency would be adversely affected if the angle of inclination exceeded a certain limit within the range studied, Figure 24.
- (f) Removal efficiency was not affected by the wider range of relative lengths used (8-120), Figure 27.

Yao concluded that circular settlers with flow velocities less than 0.54 fpm tend to perform better than those with flow velocities of higher than 0.8 fpm. In the same paper, Yao explored the idea of using a down-flow settler and compared the theoretical efficiency of the downflow

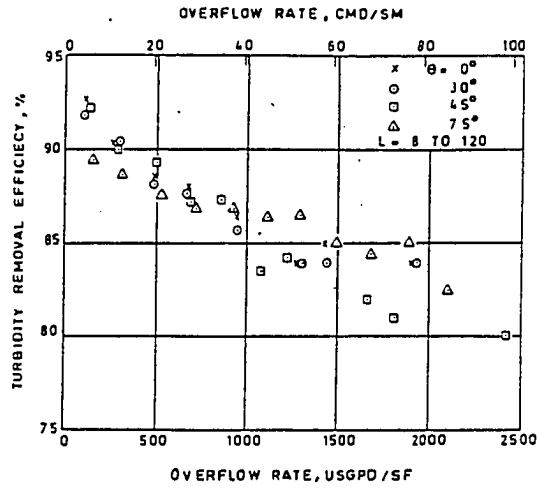

Figure 24. Turbidity removal efficiency vs flow rate using Chen's data [28]

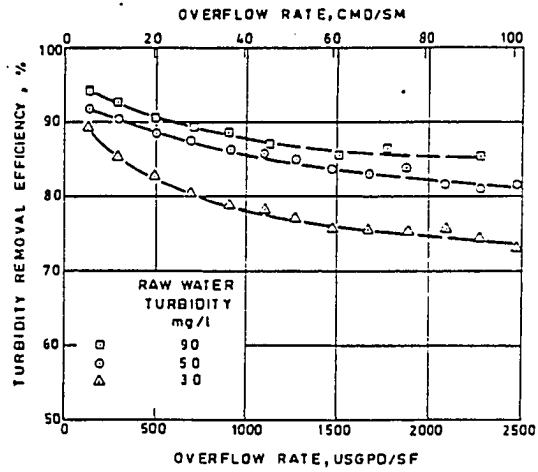

Figure 25. Inlet water turbidity vs efficiency using Chen's data [28]

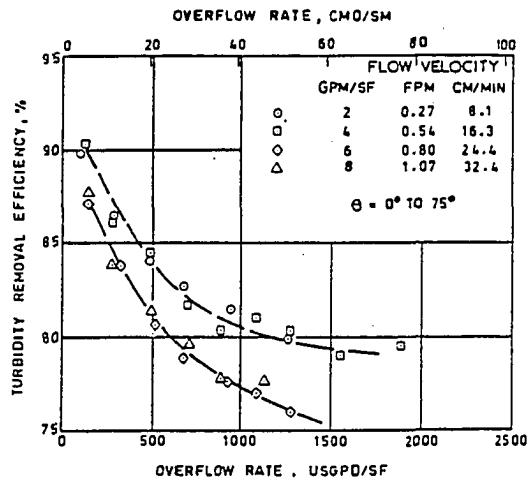

Figure 26. Flow velocity vs efficiency using Chen's data [28]

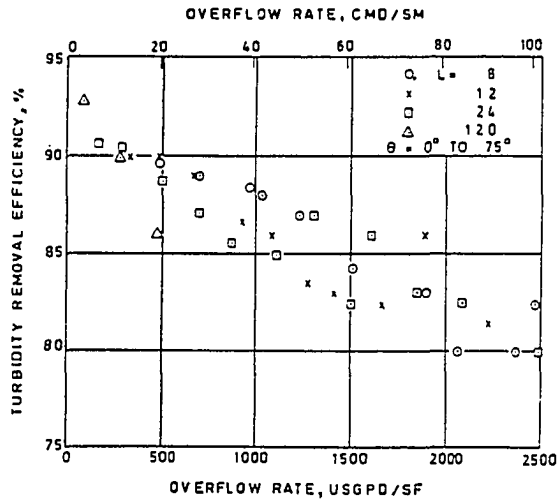

Figure 27. Tube's relative length vs efficiency using Chen's data [28]

settler versus the upflow settler. His study illustrates that down-flow settlers tend to give better performance if the settling system must rely on a self-cleaning action for sludge removal. Figure 28, after Yao, shows that a lower V_{sc} can be achieved for a down-flow settler inclined to the horizontal at 30° than for upflow settlers inclined at 60° to the horizontal when L is above 4.

Comments

Yao assumed fully developed laminar flow exists in the tubes, a condition which exists only after a transition length; in shorter tubes the flow will be a mixture of uniform and laminar flow. Since the performance of a high-rate tube settling system with uniform flow is either comparable to or better than that of a similar system with laminar flow, as indicated by the S_c values, this suggests that if the transition length is long enough (i.e., $L' \geq L$) the required particle may settle before it reaches the region in which laminar flow is fully developed. Accordingly, the laminar flow trajectory Yao proposed may not exist.

In a second paper [28], Yao's conclusions contradicted those in his first [27]; according to his theoretical studies, the tube's performance should deteriorate rapidly at angles of inclination higher than 40° , Figure 23. In the second paper, he asserted that for angles of inclination up to 75° , there was no major trend observed which altered the tube's performance. Another contradiction exists in the observation that there was no major difference in tube performance at L ranges between 8 and 1. According to his theoretical studies, tube performance should improve rapidly at L ranges between 4 and 20, and remain constant

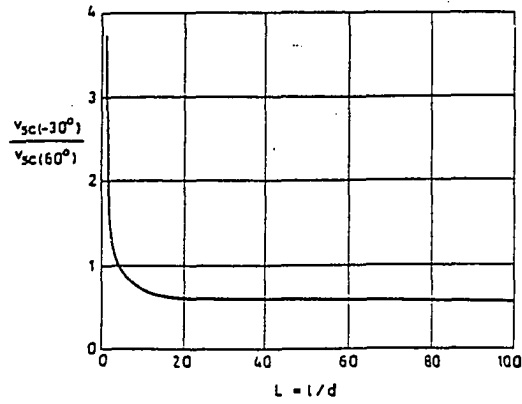

Figure 28. Performance of upflow vs downflow tube settlers after Yao [28]

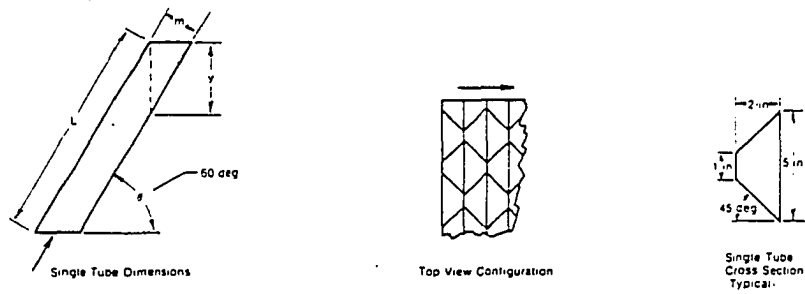

Figure 29. Suggested single tube dimensions by Willis [25]

at L values higher than 40. The only reasonable explanation for the contradiction is that Chen used flocculation, which might produce a much heavier particle. Such particles settle much faster than discrete unflocculated particles, regardless of the length and degree of inclination of the tubes.

Willis

Willis [25] stated that three basic requirements are essential to successful tube settler performance. These are:

1. Laminar (or viscous) flow conditions must exist within the tubes at the maximum flow rate required. Laminar flow is essential so that each slowly-settling floc particle within a tube maintains a steady descent to the collecting surface of the tube and is not intermittently swept upward by turbulent currents within the tube.
2. The residence time within each tube must be of sufficient duration that a floc particle entering at the extreme upper edge of the tube will have sufficient time to settle to the collecting surface a vertical distance below. (Once the particle reaches the collecting surface, the coalescing tendency between particles creates a steady sludge formation.)
3. The velocity of flow through the tubes must not exceed a critical maximum that would cause the settled sludge to lose stability and be swept out of the tube in the direction of normal flow. As a corollary, the volume of the tube must be ample to allow either sludge accumulation or a continual

discharge backward of all sludge, without critically changing the normal flow rate through the tube.

Willis' mathematical analysis is based on the fact that residence time for the flow within the tube settler, t_r , should be equal to or greater than the time required for the smallest particle which is to be removed to settle the longest vertical distance, t_s , i.e., $t_r \geq t_s$, Figure 29. Applying this concept, he derived the following equation:

$$\frac{l A_f (\sin \theta)}{KQ} \geq \beta m / \cos \theta \quad (16)$$

where:

l = tube length

A_f = the face area of the tube

K = is a factor allowing for the tubes wall thickness of the tubes plus any dead spaces around the tubes, or is

$$= \frac{\text{Total area of the tubes inlet face}}{\text{Open area in the tubes}}$$

θ = angle of the tubes to the plane of the face area

β = a constant related to the settling rate and the units of measure

m = the settler's diameter .

Willis proposed that a Reynolds number of 400 or less should be considered in tube settler design. Also, he suggested a flow rate of .25 GPM/ft², based on the tube cross-sectional area, in order to eliminate or reduce sweep-out of settled particles in both the horizontal and

inclined tubes.

His design equation led Willis to state that essentially horizontal tubes with a degree of inclination of 7.5° have the advantage of reducing the maximum drop distance by almost half, when compared with steeply inclined tubes (60°) of the same size and shape. However, he warned that the 7.5° tubes are much more susceptible to sweep-out, and that sludge will accumulate in the tube bottom, thus reducing the tube's available cross-sectional area and, consequently, increasing the flow velocity and the sweep-out tendency. He also pointed out that 60° tubes are self-cleaning, eliminating the problems associated with sludge accumulation in horizontal tubes.

Comments

Willis uses a "theoretical" approach to derive design equations for settler length. This approach is incorrect for the following reasons:

1. Willis neglects the negative component associated with the settling velocity vector.
2. Willis assumes, as Culp et al. did, a uniform velocity flow distribution; it is actually a variable velocity profile which is uniform at the inlet and parabolic after the transition length.
3. Willis' design approach was based on the assumption that the velocity of flow through the tubes must not exceed a critical maximum velocity that causes the settled particles to sweep out. If a particle could overcome the high velocity region in the central part of the tube cross-sectional area and settle, it would be impossible to sweep it out from the tube, especially at the bottom of the tube where the velocity

would approach or equal zero.

However, by incorporating Yao's S_c values and the utilization of the negative velocity component, manipulation of Willis' equations could produce equations giving the same results as Yao's for any of the settler shapes.

Hernandez and Wright

Hernandez and Wright [12] used data from several laboratories and treatment plants. The data covered a wide range of tube variables but only two angles of inclination, 5° and 60°. Lengths of 2, 4, 6, and 8 feet were used; tube diameters measured 0.5, 1, 2, and 4 inches. Raw water turbidity ranged from 15 to 450 TU; waste water solids concentrations (mixed liquor) ranged from 1126 to 2900 mg/l. Hernandez and Wright also presented data covering the effect of adding polyelectrolytes on tube settler efficiency. They concluded that tube settler performance was related to the generalized design criteria expressed in Eq. (17):

$$\frac{V^2 R}{L} \quad (17)$$

where:

V = velocity of flow in ft/sec, computed from the face velocity of the tube in GPM/ft² of the tube entrance area (the area is perpendicular to the tube).

R = hydraulic radius of the tube in ft.

L = tube length in ft.

Using this factor, they observed the following effects for the different

variables on the tube's performance:

(a) Degree of inclination

Hernandez and Wright stated that removal efficiencies appear to differ for tube angles of 5° and 60°, with the 60° tube nest producing a higher quality effluent at the same value of $\frac{V^2R}{L}$. However, only nine data points were available for the 60° tubes, vs 145 for the 5° tubes. Hernandez and Wright observed that the performance of steeply inclined tube settlers is not influenced as greatly by the physical and chemical nature of the suspended particles as is the performance of essentially horizontal units. Also, they noted that good settling results are obtained in the 60° tube nests at much higher values of $\frac{V^2R}{L}$ than are possible with 5° tube nests.

(b) Flow rate, tube length, and tube diameter:

Hernandez and Wright stated that tube performance deteriorates with increasing values of $\frac{V^2R}{L}$. Also, small diameter tubes perform better than large ones such that the hydraulic radius of the tube should be kept as small as practical, regardless of the nature of the raw water supply. Accordingly, flow rate (or velocity) becomes the critical factor. Low flow rate is essential. This, also, led to the observation that long tubes perform better than short ones.

(c) Polyelectrolytes:

Use of appropriate polyelectrolytic doses had the same approximate effect on turbidity removal as a 50 percent reduction in the flow rate; the influence of $\frac{V^2R}{L}$ is diminished by the general floc characteristics. Hernandez and Wright presented some maximum values of $\frac{V^2R}{L}$ under different treatment conditions which yield good performance depending upon the

angle of inclination, and the flocculant nature and density of the solids being removed. These values are on the order of 4×10^{-7} for 5° units, 40×10^{-7} for 60° units. Hernandez and Wright suggested the following three tables to meet these criteria.

Table 1. Maximum flow rates in GPM/ft² for steeply inclined tube ($\theta = 60^\circ$) [12]

D, in	L, ft			
	2	4	6	8
1	9	13 ^a	16 ^a	18 ^a
2	6	9	12 ^a	13 ^a
3	5	8	9	10 ^a
4	4	6	8	9

Standard Coagulants Used
No polyelectrolytes added

^aFlow rates above 9 GPM/ft² are not recommended.

Comments

Hernandez and Wright's proposed design parameter ($\frac{V^2 R}{L}$), is of questionable validity. The authors should have set limits for the variables, V, R, and L; they did not. For the same value of $\frac{V^2 R}{L}$, one may choose high R and low V and rationally expect the same tube performance as if one choose high V and low R. By similar reasoning, one

Table 2. Maximum flow rates in GPM/ft² for essentially horizontal tubes ($\theta = 5^\circ$) [12]

D, in.	L, ft			
	2	4	6	8
1	3	4	5	5.6
2	2	3	3.6	4
3	1.7	2.4	3	3.5
4	1.4	2	2.5	3

Standard Coagulants Used
No polyelectrolytes added

Table 3. Maximum flow rates in GPM/ft² for settling activated sludge mixed liquors ($\theta = 60^\circ$) [12]

D, in.	L, ft			
	2	4	6	8
1	2	3	3.6	4
2	1.4	2	2.5	3
3	1.2	1.7	2	2.4
4	1	1.4	1.8	2

should expect the same performance from tubes having large L and high R values as one would expect from a short tube with a small diameter; the

two tubes having the same $\frac{V^2R}{L}$ values. However, experimental results showed that these conditions do not exist. Long tubes with large diameter perform less well than short tubes of small diameter. Also, Hernandez and Wright [12] set values for $\frac{V^2R}{L}$ for alum-treated water and activated sludge mixed-liquor which simply do not apply to other types of treatment, such as iron-treated water and/or polymer-treated water and lime-softened water.

Van Vliet

Van Vliet [22] installed both a tube and plate modules in a primary clarifier, Figure 30. The floc blanket in the primary clarifier was operated just below the module's intake. The tube unit had a module-end cross-sectional area of 0.93 m^2 ; the vertical height of the tube bundle was 0.5 m. The tubes were inclined at 30° to the vertical (i.e., 60° to the horizontal), and had a square cross-section with 50 mm wall-to-wall spacing. The plate unit had a module-end cross-sectional of 0.29 m^2 consisting of corrugated fiberglass plates, spaced 20 mm apart and inclined at 30° to the vertical. The water velocity through the two modules ranged from 3 m/hr to 12 m/hr.

Van Vliet tested the tube settlers and inclined plates using water treated with four different flocculants:

- (a) Ferric chloride dosage of 5 mg/l (as Fe^{3+}) plus an anionic polyelectrolyte dosage of 1 mg/l.
- (b) Ferric chloride, as a concentration of 5 mg/l only.
- (c) Anionic polyelectrolyte, at a concentration of 1 mg/l only.
- (d) No flocculant.

The flocculant was applied ahead of the primary clarifier. Figure 31 illustrates the experimental results. Van Vliet reported that the tube or plates performed better than the clarifier, and removed an additional 60 percent of the turbidity from the normal clarifier effluent. Performance of the plate module was marginally better than that of the tube module.

Van Vliet proposed the following model:

$$TM = \alpha \exp (\beta/T_A) TC \gamma FR^\delta + \theta \quad (18)$$

where:

TM = fitted turbidity of the overflow from tube or plate module, FTU.

TA = absolute temperature, K° (288 < TA < 298).

TC = turbidity of primary clarifier overflow, FTU 1 < TC < 6.

FR = ratio of module hydraulic loading to primary clarifier hydraulic loading (1.5 < FR < 6.0).

The symbols α , β , γ , δ , and θ represent model coefficients arising from the modeling procedure and assuming a specific set of values for the tube and plate module at each flocculant dose. The model was developed from data fitting analysis, using an IBM digital computer. The model indicates that turbidity removal efficiency should increase with increases in the clarifier's effluent turbidity. The effect of the flocculant doses was described by Van Vliet as showing:

"There appeared to be very little difference in module performance for the two low dosing conditions, i.e., in which only the ferric chloride was used. These

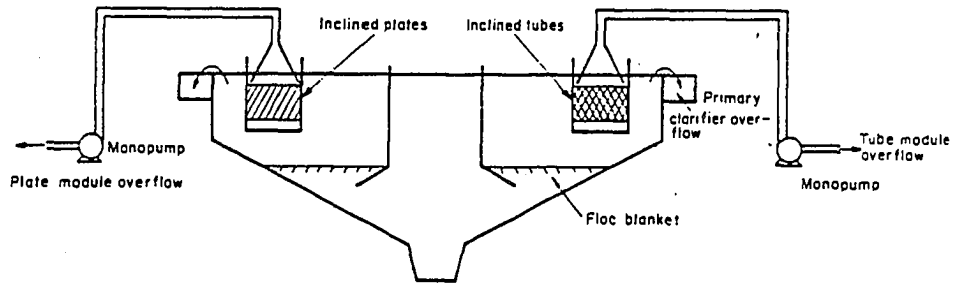

Figure 30. Schematic diagram of modules in primary clarifier for the experiment conducted by Van Vliet [22]

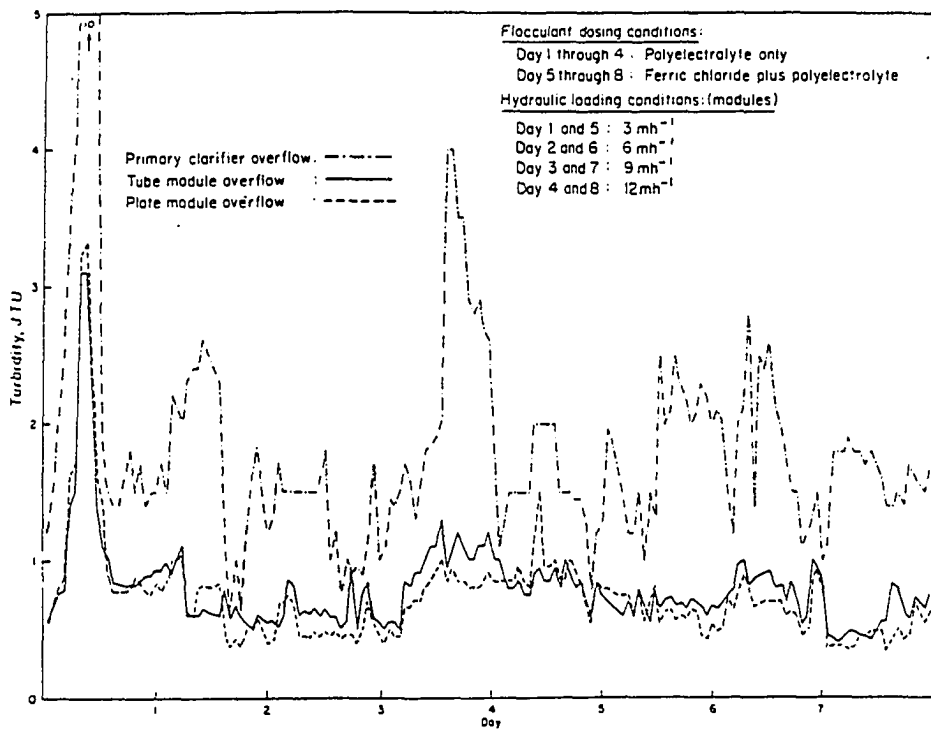

Figure 31. General performance of the clarifiers and the modules in Van Vliet experiment [22]

two conditions were therefore considered to be equivalent in respect of clarification within the modules. Although the performance of the modules deteriorated as flocculant dosage decreased, they nevertheless produced consistently better overflow clarities than the primary clarifier, even at zero flocculant dosage."

Comments

Van Vliet's approach applies only to the condition and configuration in which he used the tube settlers. His model's equation was restricted nonhomogenous. One cannot use or apply this equation to design another system with different water treatments. His conclusion that the plate module performed better than the tube module is misleading, since the plate spacing was less than half the tube diameter, helping to improve plate efficiency.

El-Baroudi and Fuller

El-Baroudi and Fuller [8] used tracer dispersion techniques to study the changes in hydraulic characteristics brought about by selected high rate settler configurations as compared to those of the standard or conventional counterparts. They found that increasing surface area will increase removal efficiency and that introducing tubes and plates will induce optimum hydraulic characteristics, thus enhancing sedimentation. They guided the flow to reduce water depth and Reynolds numbers, thereby creating better laminar flow conditions with better velocity distribution.

El-Baroudi and Fuller divided the high rate settling tank under ideal hydraulic conditions into three zones, Figure 32. These were:

(a) The inlet zone, V_1 , in which a complete mixing condition was encountered wherein all properties were the same at any given instant, and equal to the inlet zone's effluent.

(b) The horizontal flow in volume 2, (V_2); flow is laminar and velocity is uniform along the water depth, so no turbulent mixing takes place. This horizontal velocity is reduced linearly along the length of this zone because of the uniform diversion of flow to volume 3.

(c) The upward flow in volume 3, (V_3), in which the inclined tubes or plates are placed, is laminar with a uniform velocity.

The experiment was conducted using a model settling tank divided into two units, as shown in Figure 33. One unit worked as a standard sedimentation tank. It was placed in parallel with the second unit, which represented a high rate settler. The tank is described in more detail in the reference. El-Baroudi and Fuller presented a mathematical and graphical solution in which various values for $V_1 + V_2$ were assumed and $(t/T)_m - V_3$ were calculated for various ratios of $\frac{V_1}{V_1 + V_2}$. Also, values of $(C/c)_m$ were calculated and plotted for assumed $V_1 + V_2$

fractions and $\frac{V_1}{V_1 + V_2}$ ratios, where:

C = the time elapsed after injection of tracer weight divided by $(V_1 + V_2 + V_3)$.

c = the desired efficiency concentration.

m = maximum tracer concentration values in effluent.

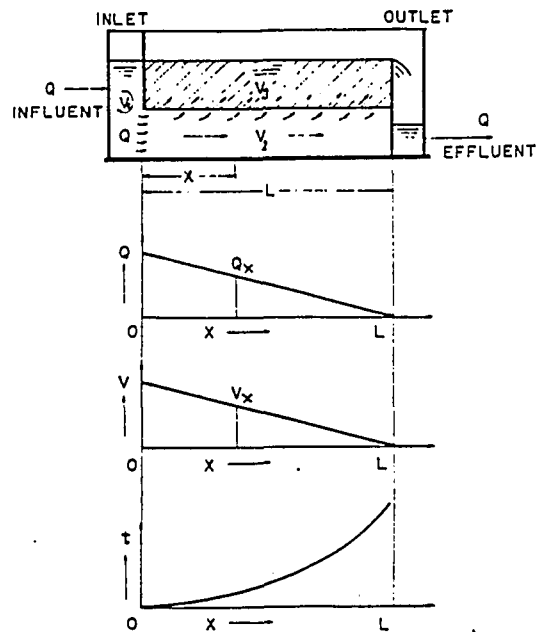

Figure 32. Sedimentation volume classification according to El-Baroudi and Fuller [8]

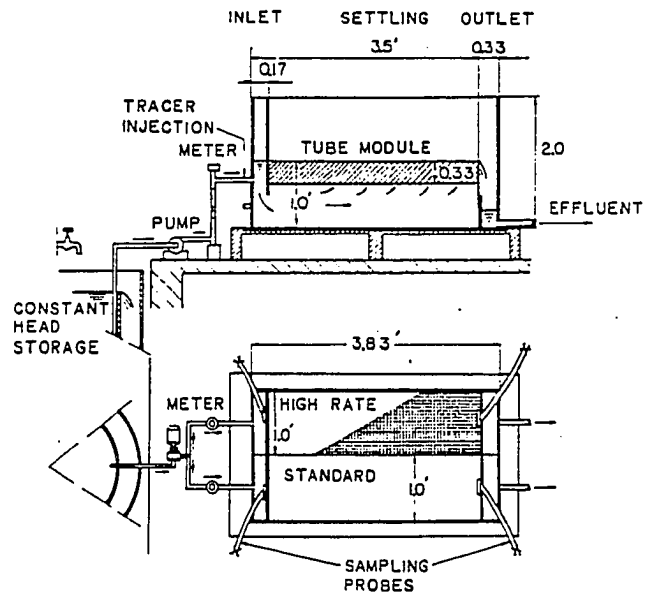

Figure 33. Schematic diagram for the model tank used in El-Baroudi and Fuller experiment [8]

T = tank detention time.

El-Baroudi and Fuller found the high rate model to demonstrate rather poor detention characteristics and concluded that the tapered flow volume (V_2) has an effect on tracer dispersion which is equivalent to that of a completely mixed volume. The experiments emphasized the importance of having an adequate volume (V_2) beneath the tube bundle and demonstrated that this volume should be as large as 70% of the total tank volume to increase the tube bundle's efficiency. The large volume is essential to reduce the flow velocity in this part of the tank. Headloss for the flow in this volume will be minor; hence, differences in flow across the tubes at the first portion of the bundle will not be significantly lower than at the far end of the bundle.

Comments

El-Baroudi and Fuller did not consider that a fourth volume is required at the top of the tube's effluent. Their work is in error because this volume is essential to control the effluent flow for the tube in the model tank. This is why they found the high rate model to demonstrate relatively poor detention characteristics. This volume should be inserted in the model if the model is to be accurate in reflecting tube settler performance.

Factors Affecting the Performance of Tube Settlers

Several factors noted in research studies discussed [5,6,12,21,22, 25,27,28] affect the performance of tube settlers. These are:

(a) Flow velocity and flow regime: All researchers agree that the flow regime should be laminar. Some [6] have set a Reynolds number

limit (based on hydraulic radius) of 500; others have set limits on flow velocity (0.6 fpm by Yao; 0.33 fpm by Willis, and 1.2 fpm by Hernandez and Wright).

(b) Tube diameter and tube length: All the researchers agree that smaller tube diameters and longer tube lengths yield better performance. Culp et al. suggested that tube diameters should be in the range of 1 to 4 inches and tube lengths should be in the range of 2 to 4 feet. Willis stated that a tube diameter of two inches is considered economical and reasonable. Hernandez and Wright suggested tube diameters of 1 to 4 inches and lengths of 2 to 8 feet.

(c) Tube cross-sectional shapes: Tube cross-sectional shape affects performance. Yao found that parallel plates perform better than circular or square conduits. Willis found that wide horizontal plates are hydraulically unstable.

(d) Inlet and outlet arrangement: The design of a proper inlet and outlet arrangement is as important as the design of the tube settler itself. To utilize the tube's capacities to remove suspended solids, one must ensure equal distribution of the flow through the tube bundle. Both Willis and El-Baroudi showed the importance of having a good design for the inlet and outlet for the tubes.

(e) Degree of inclination: Only the essentially horizontal and steeply inclined tube configurations are defined by the degree of inclination; these are at angles of ($\theta = 0 - 7.5^\circ$ and $\theta = 45 - 60^\circ$, respectively). Theory states that essentially horizontal tubes yield better performance than steeply inclined tubes (Willis, [25]); however, steeply inclined tubes are more self-cleaning. Hernandez and Wright

reported that for the same values of $\frac{v^2 R}{L}$, the steeply inclined tubes yield better performance than essentially horizontal tubes. Yao [28], however, concluded, based on an analysis of Chen's data, that the degree of inclination has little effect on tube performance in the range of 0° to 75°.

(f) Entrance length: In the entrance region, a nearly inviscid upstream flow converges and enters the tube. The initially rectangular velocity distribution in this region is gradually transformed into a parabolic distribution by the action of viscous forces further downstream. This transformation takes place in the transition relative length which Yao considers equal to $0.058 \frac{v_o d}{\nu}$. The transition, or entrance, length is mentioned only by Yao, who believes that little settling occurs in this portion of the tube. He recommends that the required tube length calculated from his model be increased by the transition length if the transition length is less than the actual length calculated from the model. On the other hand, if the transition length is greater than the calculated tube length, the tube length provided in practice should equal two times the calculated tube length. All researchers agree that the use of alum and/or polymers increases removal efficiency. They found that the amount of flocculant required depends on the type and concentration of the suspended solids. Flocculation increases particle settling velocity by increasing particle size and mass.

Summary

Previous work in tube settler design has characteristically shown poor experimental design in conducting tests to evaluate design

models. In some cases (i.e., Yao), no experiments were in fact performed. However, all researchers have demonstrated that long, small diameter tubes yield better performance than short, large-diameter tubes. While there is substantial variance in practical use of tube diameters and lengths, a tube diameter of two inches and a tube length of four feet or more are commonly held desirable. The actual variations in tube length and diameter may be accounted for by differences in experimental method and purpose.

Tube settlers have the advantage of increasing the settlement capacity of a sedimentation basin while making no increase in the physical size of the basin. This was first demonstrated by Camp and confirmed by Culp. Since their early work, the essentially horizontal and steeply inclined tube configurations have emerged as basic patterns of design. While both patterns offer advantages for specific uses, the steeply inclined form is self-cleaning while the essentially horizontal is not.

The research summarized herein presents four design models having varying degrees of efficiency.

UNSETTLED QUESTIONS

The literature review suggested three important questions requiring further investigation. These are: a) What is the actual particle trajectory in the tube?, b) Will the design for the essentially horizontal tubes be the same as that for the steeply inclined tubes?, and c) What is the best inlet and outlet arrangement for the essentially horizontal tubes configuration? This portion of the research will answer to some extent these unsettled questions.

Actual Particle Trajectory

Studying velocity profiles in circular tubes, Langhaar [15] focused on the change of the velocity profiles from a uniform velocity distribution at the entrance to a fully developed laminar parabolic velocity profiles at some distance along the tube. By using an equation developed by Langhaar, derived from Bessel functions, Table 4, and the hyperbolic Bessel functions, the velocity profiles for laminar flows in a tube can be calculated. Langhaar's equation states that:

$$\lambda = [I_0(\gamma) - I_0(\gamma q)] / I_2(\gamma) \quad (19)$$

where $\lambda = w/v_{av} =$ dimensionless axial velocity

$I_0(\gamma) =$ The hyperbolic Bessel function of 0-order for γ value

$I_0(\gamma q) =$ The hyperbolic Bessel function of 0-order for γq value

$I_2(\gamma) =$ The hyperbolic Bessel function of 2nd-order for γ value

$w =$ components of the fluid velocity

$v_{av} =$ average velocity in the tube

$\gamma = \beta a =$ dimensionless parameter

Table 4. Langhaar constants [15]

γ	20.00	10.00	9.00	8.00	7.00	6.50
σ	0.00082	0.00418	0.00541	0.00722	0.00997	0.01188
γ	6.00	5.50	5.00	4.50	4.00	3.50
σ	0.0143	0.0174	0.0214	0.0267	0.0335	0.0426
γ	3.25	3.00	2.75	2.50	2.25	2.00
σ	0.0483	0.0549	0.0625	0.0715	0.0821	0.0947
γ	1.85	1.70	1.55	1.40	1.30	1.20
σ	0.1034	0.1132	0.1241	0.1365	0.1459	0.1560
γ	1.10	1.00	0.90	0.80	0.70	0.60
σ	0.1671	0.1795	0.1934	0.2091	0.2270	0.2479

$q = r/a =$ dimensional radial co-ordinate

$a =$ tube radius

$\beta =$ certain parameter function of z alone

$\sigma = z/aR =$ dimensionless axial co-ordinates z , $r =$ cylindrical co-ordinates of the point z, x

$RN = V_{av} a/\nu =$ Reynolds number (according to Langhaar)

$\nu =$ kinematic coefficient of viscosity

The distance between two velocity profiles can be obtained using the following equation:

$$L = (\sigma_i - \sigma_{i-1}) a RN \quad (20)$$

where $i =$ number of the velocity profile section.

Figure 34, after Langhaar, shows some of the calculated velocity profiles. Langhaar found that the transition length required for developing a complete laminar parabolic velocity profiles can be obtained from the following equation:

$$L = 0.058 a RN . \quad (21)$$

The parabolic velocity profiles will remain constant after the transition length until the end of the tube is reached. Experimental work confirms the validity of these equations (White, [24]). The works of Langhaar and White proves that the assumption of Culp and Hansen [5] and Willis [25] is not valid; i.e., flow through the tube is not uniform, and therefore the particle trajectory proposed by them is incorrect.

The particle will begin to settle as soon as it enters the tube

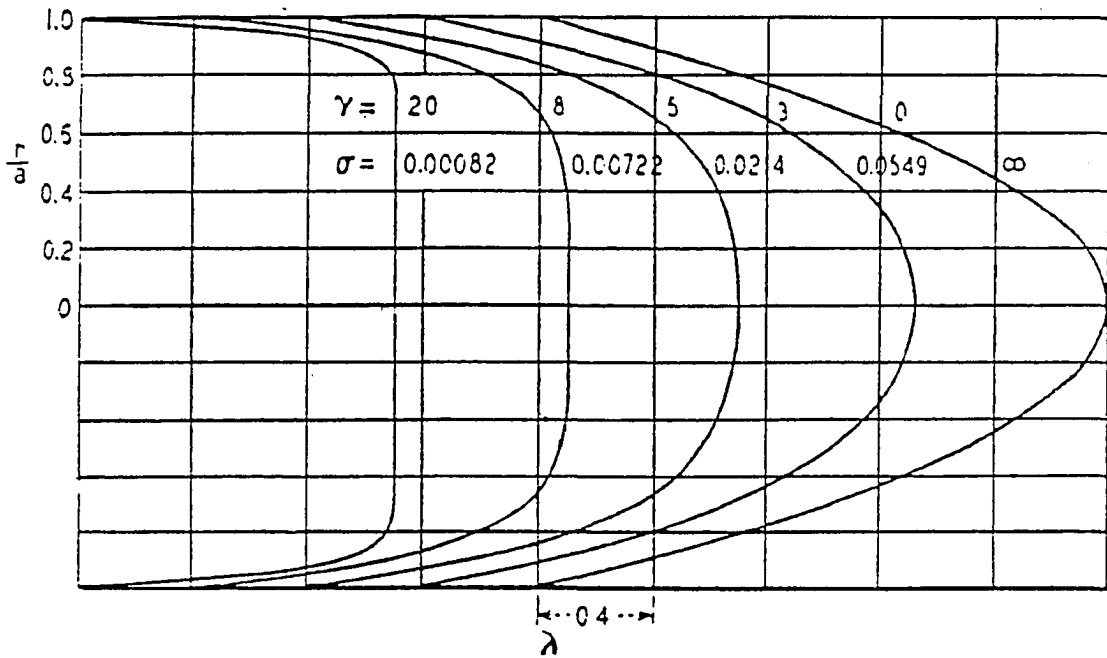

Figure 34. Langhaar calculated velocity profiles [15]

because the flow in the transition length is laminar. One discovers that Yao's particle trajectory is not applicable by following the particle path across the tube and taking into consideration the variation in velocity profile through the tube and its changes along the transition zone.

As previously mentioned, Yao assumed a particle trajectory in the fully laminar parabolic velocity profile part of the tube. However, a particle may have settled part of the way through the tube diameter or it may be completely settled before it reaches the end of the transition length. The position of the particle in the tube with regard to the transition length will depend on the average flow velocity and on the particle settling velocity. If the average flow velocity is low and the particle's settling velocity is high, one can predict that the particle will settle before the end of the transition length. On the other hand, if the tube flow velocity is high and the particle's settling velocity is low the particle may settle in the region of the fully developed laminar velocity profile, i.e., after the transition length. Therefore, if one adds the transition length to the design length using Yao's equation, as recommended by Yao, one will overestimate the required tube length. Therefore, the question of how the particle trajectory may be calculated, and hence, how the particle settling length may be derived, must be answered. The author has developed a model which determines both the particle trajectory and the required tube settling length, and which considers the velocity profile variation through the tube calculated using the equations developed by Langhaar.

The Fadel model

In order to use the author's model, one must calculate the different velocity profiles and the distance between these profiles along the tube length by using Table 4 and Eq. 19. These calculations are shown in sample form in Appendix B. Basically, if the local velocities through the tube are known, the particle trajectory and the tube length may be calculated by the following steps:

1) Assume that the particle which it is desired to remove completely will enter the tube at the upper most point "A" in section I, Figure 35.

2) Assume that the particle will reach point "B" in section II by assuming settlement of distance x_1 in the process.

3) Assume the distance x_1 equal to $0.05D$ (D is now the tube diameter).

4) From the calculated velocity profiles find the four local velocities $V_I, V_I', V_{II}, V_{II}'$.

5) By assuming that the particle will move from point "A" to "B" with a velocity equal to the average of the local velocities, i.e., $V_{av} = (V_I + V_I' + V_{II} + V_{II}')/4$, the time required for the particle transfer from "A" to "B" can be calculated:

$$t = L/V_{av}$$

6) By knowing the particle settling velocity, V_{sc} , the actual settling depth can be calculated:

$$x_a = V_{sc} \times t$$

7) If $x_a >$ or $<$ x_1 -assumed, then assume a new x equal to the depth x_a calculated from step 6., and repeat steps 2 through 6 until the x_a ~

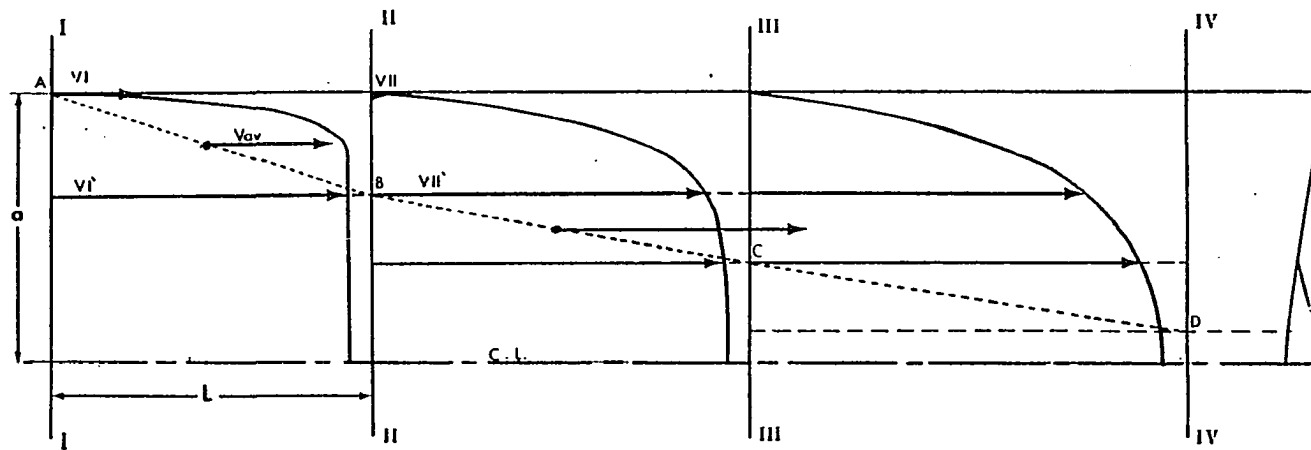

Figure 35. Schematic diagram illustrates the particle path inside the tube using Fadel's model

x_1 assumed.

8) When $x_a \sim x_1$ -assumed, the particle will be considered moved to the calculated new point "B".

9) The velocity VII' will be the velocity VI for the part of the tube between section II and III.

10) Repeat step 2 through 8 for the particle movement from point "B" to "C," and so on, until the particle settles to the bottom of the tube at some distance along the tube.

11) The summation of the L's until settling occurs will equal the required tube settling length.

If the particle does not reach the tube bottom prior to reaching the end of the transition length, the following equation should be used to determine, mathematically, the remaining length required for the particle to reach the tube bottom:

$$L_r = d[8.0(V_{av}/V_{sc} \cos \theta)(Y_r^2/2.0 - Y_r^3/3) - Y_r \tan \theta] \quad (22)$$

Where $Y_r = \frac{d - x_s}{d}$

x_s = the particle's settled depth from the tube's top at the end of the transition length.

This equation was developed by Yao as a general equation for the trajectories of all the particles entering the tube and assumes a fully developed flow velocity profile.

The author's model is easy to follow and use, but the calculation is time consuming. Accordingly, a computer program is used to solve the model, Appendix A. Samples of the calculated trajectories and tube

lengths obtained using this model can be found in the chapter entitled "Theoretical Study." Users of the computer program should enter the desired flow velocity, particle settling velocity, water temperature, water viscosity, and the required tube diameter to obtain the particle trajectory and tube length from the computer program.

The model may be applied to any tube's cross sectional shape. The only changes required are the velocity profiles for the new cross-section and the " σ " values to be used. This can be achieved by adding new data files to the computer, similar to the FOR010.DAT, and FOR01.DAT. The FOR010.DAT file, shows the ratio of the local velocities for the circular tube to the average velocity; the FOR011.DAT file shows the σ values.

Essentially-Horizontal vs Steeply-Inclined Tube

All previous researchers [5,6,12,25,27,28] used the same model for designing both essentially-horizontal and steeply-inclined tube configurations, mentioning that the essentially horizontal tubes theoretically yield better performance. All researchers agreed that practically the steeply inclined tube removal efficiency was higher than the essentially horizontal tube's, however, and stressed the importance of the big advantage of the steeply inclined tube's self-cleaning characteristics, noting that the horizontal tubes requires a periodic flushing.

Of course, the two design configurations have significant differences. The steeply inclined tubes are nearly always in a steady state operating condition, i.e., changes in the flow velocity and the effective tube diameter as a function of time are negligible because the

steeply inclined tubes are self-cleaning. In self-cleaning tubes, the particle settling on the tube bottom will immediately slide down and exit the tubes. On the other hand, the essentially horizontal tube stores the settled particles until the tube is backflushed to wash the settled particles out of the tube. These stored particles occupy part of the tube volume, which decreases with time, reducing the available flow depth and increasing the flow velocity. This means that the essentially horizontal tubes are not in a steady state condition, i.e., both the velocity and the effective settling depth change with time.

When a designer uses the same model for designing both tube configurations, he underestimates the tube diameter and tube length required for the essentially horizontal tubes. The tube diameter calculated by the designer will be for a clean tube; this diameter will change with time. As more particles are stored at the tube bottom, the velocity of the flow increases and particles begin to sweep out due to increasing the shear on the stored particles surface. This is why horizontal tubes seem less efficient than steeply inclined tubes. If the design procedure included the required storage volume in the essentially horizontal tubes, the tubes would yield performance equivalent to that of steeply inclined tubes.

Another significant difference between the two configurations is in their application in the field. The steeply inclined tubes are used primarily as a polishing step in water treatment; most large, heavy particles settle in the large inlet volume provided for this configuration to ensure adequate flow distribution. The low settling velocity particles will settle in the tubes. Essentially horizontal

tubes remove all the suspended solids in water, permitting little or nothing to settle in the inlet zone ahead of the tube modules.

From an economic point of view, the essentially horizontal tubes offers an advantage in that the tank required will be much smaller than that required for the steeply inclined tubes. The difference in the volume is significant, because: a) The steeply-inclined tubes require a larger inlet and outlet volume, and b) The required cross sectional area for steeply inclined tubes is larger than that for the essentially horizontal tubes for the same ratio of average flow velocity to particle settling velocity. However, an important point which must be considered when comparing the two configurations is the fact that both labor and backflushing water are required to backflush or clean the essentially horizontal tubes.

Inlet and Outlet Arrangement

As discussed previously, the proper design of the inlet and outlet arrangement is as important as the design of the tubes themselves. Therefore, Willis [25] proposed an inlet and outlet arrangement for the steeply-inclined tubes consisting of an inlet piping system similar to the under drain of a rapid sand filter and an outlet having troughs with an adjustable weir, Figure 15. His proposed inlet/outlet flow control system makes good hydraulic sense and will improve the performance of steeply-inclined tubes. The inlet piping system will reduce the large inlet volume required by use of the inclined tubes, improving the flow distribution through the tube bundle; the outlet system will reduce flow short-circuiting in the tank. Figure 36 shows the upper surface of an

inclined tube bundle in a sedimentation tank; Figure 36a shows the surface condition at the beginning of service, and Figure 36b shows the surface condition after one month of service. A big portion of the available surface area of the tube was plugged, indicating that the flow was unevenly distributed.

Unfortunately, little information is available in the literature about the operation problems and performance of essentially horizontal tube sedimentation tanks in practice. The only configuration found in the literature is the system designed by Neptune-Microfloc and shown in Figure 11. Culp et al. mentioned that an uneven flow distribution was obtained in self-orificing tubes; hydraulically, an even flow distribution should be obtained using this system. The explanation for the observed distribution may be that large heavy particles entered the lower portion of the tube bundle, plugging it faster than the upper portion where smaller particles predominated.

The author suggests the inlet-outlet arrangement shown in Figure 37. The staggered baffles force the flow to be evenly distributed through the bundle. The inlet zone should be as short as possible, and the fluid in this zone should be completely mixed to keep the particles in suspension. The staggered outlet baffle will prevent short-circuiting from taking place in the tank. In order to prove the adequacy of this arrangement as well as Willis arrangement for steeply inclined tubes, field application is required.

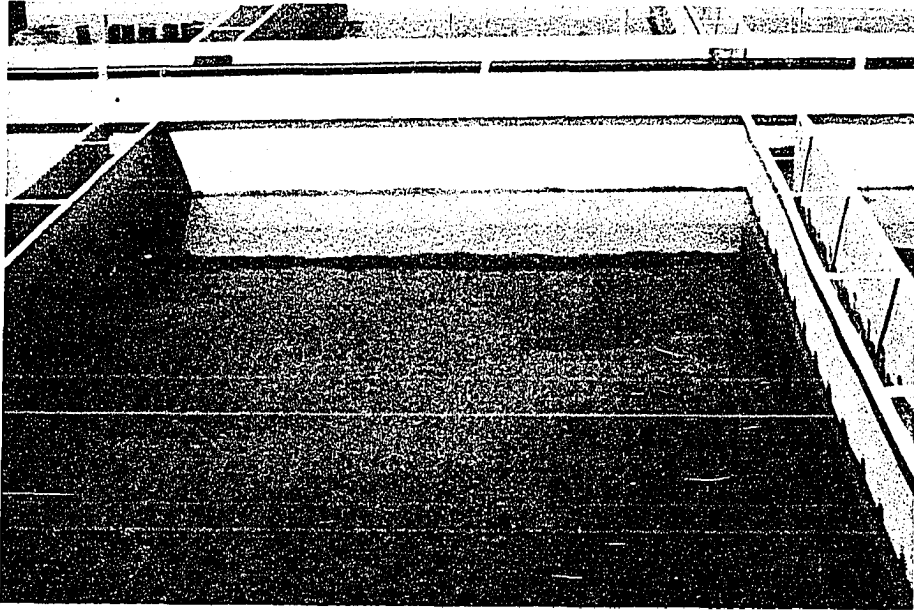

a) At the beginning of service

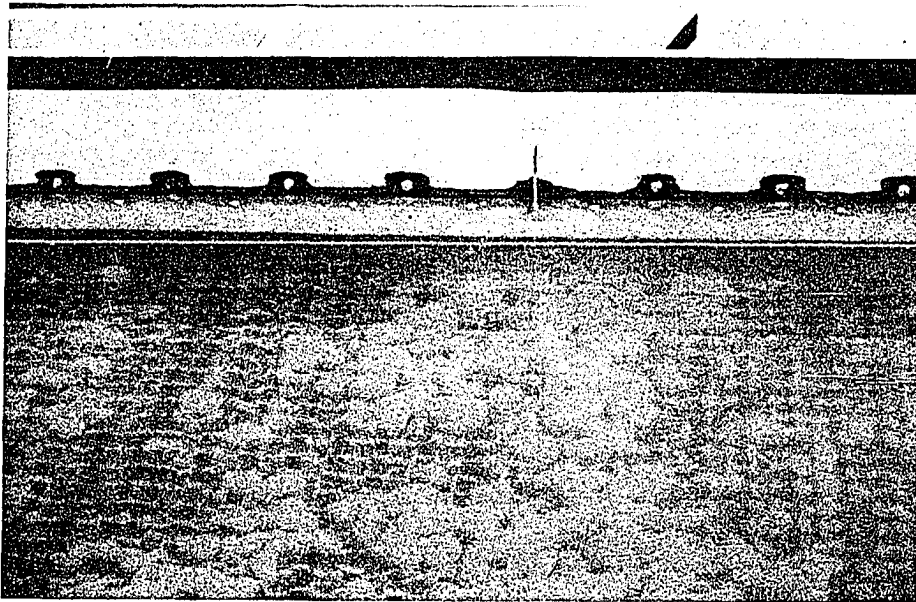

b) After one month of service

Figure 36. The upper surface of a steeply inclined tube bundle in a sedimentation tank

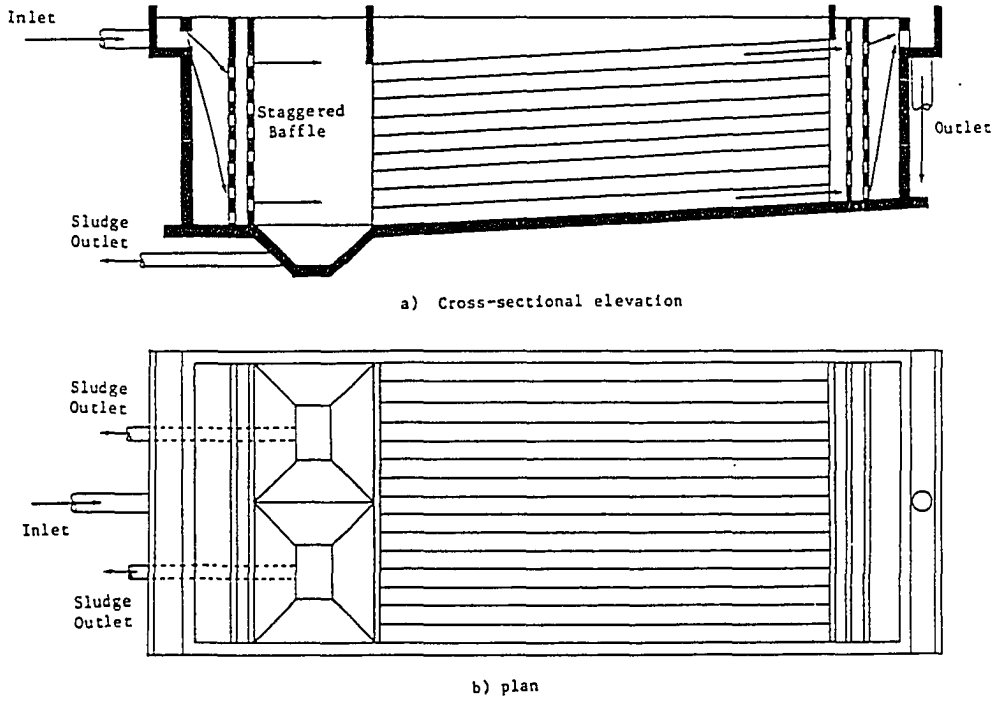

Figure 37. Suggested inlet-outlet arrangement for an essentially horizontal tube bundle in a sedimentation tank

THEORETICAL STUDY

In order to evaluate the effects of significant variables on the design of tube settlers, six design examples are presented in this section. The Fadel model was used and the calculations were made using the author's computer program described in Appendix A. The computer output predicts the particle location inside the tube at any time, i.e., the depth the particle settles versus the distance along the tube length that it moves.

Example 1:

Conditions:

Tube diameter = 3.0 inches
 Average flow velocity = 1.5 fpm
 Particle settling velocity = 0.8 fpm
 Water temp. = 90°F
 Degree of inclination = 5 deg.
 Transition length = 8.87 ft

Settl. depth (ft)	Detention time (min)	Settl. length (ft)
0.021	0.026	0.031
0.081	0.101	0.156
0.100	0.126	0.202
0.129	0.161	0.268
0.170	0.213	0.371
0.200	0.251	0.443
0.250	0.314	0.500

Example 2:

Conditions:

Tube diameter = 3 inches
 Average flow velocity = 1.5 fpm
 Particle settling velocity = 0.4 fpm
 Water temp. = 90 F.
 Degree of inclination = 5.0 deg.
 Transition length = 8.87 ft

Settl. depth (ft)	Detention time (min)	Settl. length (ft)
0.012	0.031	0.031
0.049	0.122	0.160
0.059	0.148	0.206
0.073	0.184	0.275
0.094	0.237	0.380
0.109	0.272	0.453
0.126	0.316	0.545
0.148	0.371	0.664
0.175	0.441	0.817
0.221	0.554	1.019
0.250	0.627	1.069

Example 3:

Conditions:

Tube diameter = 3 inches
 Average flow velocity = 1.5 fpm
 Particle settling velocity = 0.2 fpm
 Water temp. = 90 F.

Degree of inclination = 5 deg.
 Transition length = 8.87 ft.

Settl. depth (ft)	Detention time (min)	Settl. length (ft)
0.007	0.035	0.032
0.030	0.152	0.161
0.036	0.181	0.209
0.044	0.220	0.278
0.056	0.278	0.385
0.063	0.316	0.459
0.072	0.362	0.552
0.084	0.419	0.671
0.098	0.489	0.826
0.115	0.577	1.031
0.137	0.686	1.293
0.165	0.831	1.645
0.165	0.927	1.865
0.211	1.060	2.120
0.250	1.254	2.278

Example 4:

Conditions:

Tube diameter = 3 inches
 Average flow velocity = 1.5 fpm

Particle settling velocity = 0.1 fpm
 Water temp. = 90 F.

Degree of inclination = 5 deg.
 Transition length = 8.87 ft.

Settl. depth (ft)	Detention time (min)	Settl. length (ft)
0.004	0.038	0.032
0.019	0.194	0.162
0.022	0.229	0.210
0.028	0.278	0.280
0.034	0.344	0.387
0.038	0.388	0.461
0.044	0.442	0.555
0.050	0.506	0.676
0.058	0.586	0.831
0.068	0.685	1.036
0.080	0.803	1.301
0.095	0.952	1.654
0.104	1.040	1.876
0.114	1.140	2.132
0.125	1.251	2.427
0.138	1.381	2.777
0.153	1.534	3.188
0.172	1.725	4.016
0.186	1.868	4.396
0.204	2.053	4.820
0.204	2.407	4.820
0.250	2.510	4.844

Example 5:

Conditions:

Tube diameter = 3 inches
 Average flow velocity = 1.5 fpm
 Particle settling velocity = 0.05 fpm
 Water temp. = 90 F.
 Degree of inclination = 5 deg.
 Transition length = 8.87 ft.

Settl. depth (ft)	Detention time (min)	Settl. length (ft)
0.002	0.040	0.032
0.012	0.249	0.163
0.015	0.293	0.211
0.018	0.354	0.280
0.022	0.441	0.388
0.025	0.495	0.463
0.028	0.561	0.557
0.032	0.641	0.678
0.037	0.738	0.833
0.043	0.859	1.040
0.050	1.002	1.305
0.059	1.179	1.659
0.064	1.284	1.881
0.070	1.399	2.140
0.076	1.527	2.434
0.083	1.670	2.785
0.091	1.832	3.198

0.100	2.016	3.689
0.107	2.140	4.030
0.113	2.276	4.409
0.121	2.425	4.833
0.129	2.593	5.317
0.135	2.719	5.683
0.142	2.856	6.076
0.150	3.008	6.508
0.159	3.181	6.991
0.169	3.384	7.533
0.181	3.630	8.144
0.197	3.948	8.841
0.250	5.019	10.014

Example 6:

Conditions:

Tube diameter = 3 inches

Average flow velocity = 1.0 fpm

Particle settling velocity = 0.05 fpm

Water temp. = 90 F.

Degree of inclination = 60 deg.

Transition length = 5.95 ft

Settl. depth (ft)	Detention time (min)	Settl. length (ft)
0.001	0.040	0.020
0.009	0.352	0.104

0.010	0.413	0.135
0.012	0.492	0.179
0.015	0.603	0.250
0.017	0.674	0.296
0.019	0.760	0.356
0.022	0.864	0.434
0.025	0.988	0.533
0.029	1.141	0.665
0.033	1.323	0.835
0.039	1.547	1.061
0.043	1.677	1.203
0.046	1.821	1.368
0.049	1.979	1.557
0.054	2.156	1.781
0.059	2.354	2.045
0.064	2.576	2.359
0.068	2.722	2.576
0.072	2.882	2.820
0.076	3.053	3.092
0.081	3.241	3.400
0.085	3.380	3.635
0.088	3.525	3.887
0.092	3.682	4.163
0.096	3.853	4.472
0.101	4.042	4.818
0.106	4.250	5.210

0.112	4.484	5.656
0.250	10.000	13.113

The examples were selected to present different particle trajectory possibilities. The first example illustrates the effect that a low average flow velocity to particle settling velocity ratio has on the particle trajectory. Only 7 velocity profiles were used in calculating the required settling length because the particle settles a short distance from the tube entrance. Examples 2, 3, and 4 illustrate the effect on the required settling length of increasing the ratio of the average flow velocity, V_{av} , to the particle settling velocity V_{sc} . As the ratio V_{av} to V_{sc} increases, the number of velocity profiles also increases so that, in case of example 5, the required settling length is larger than the transition length of the tube. For this reason, the last integration step in the computer output was obtained by calculation only (Eq. 22).

The transition length for the 3 inches tube with an average flow velocity of 1.5 fpm and water viscosity of 0.00001 (90F) ft/sec^2 is 8.87 ft. The remaining length, 1.173 ft, represent the distance where the fully developed parabolic velocity profile influences the particle traveling in the tube. In example 6, the degree of inclination was changed from 5 to 60 degrees.

The particle's trajectory can be obtained by drawing the relationship between the particle settling depth versus the distance it moves in the tube. Figures 38, 39, 40, and 41 show the particle trajectories developed in examples 1 through 4.

Particle trajectories shown in the last four figures illustrate the effect that variation in the flow velocity profiles has on the particle path inside the tube. At the tube entrance, where the velocity distribution is close to uniform across the tube, the particle trajectory is close to a straight line. In the second part of the tube, the particle trajectory departs from a straight line when the velocity distribution profile is closer to a parabola than it is to the uniform velocity distribution at the entrance.

Factors Affecting Tube Performance Using Fadel's Model

Five factors affecting tube performance may be predicted from the computer solutions of the model. These are:

1) Tube diameter

Figure 42 presents the effect of increasing the tube diameter on the required tube length. The conditions of flow velocity, particle settling velocity, degree of inclination, and temperature remain constant. As expected, large tube diameters require longer tubes; small diameter tubes yield better performance.

2) Degree of inclination

Figure 43 shows the effect of the degree of inclination on the required tube length. Angles in the range of 5 to 20 degrees from the horizontal have little influence on the required tube length. However, the required tube length increases significantly at angles of 20 degrees or more; at 60 degrees, the required length is almost twice that of tube on an inclination of 5 degrees.

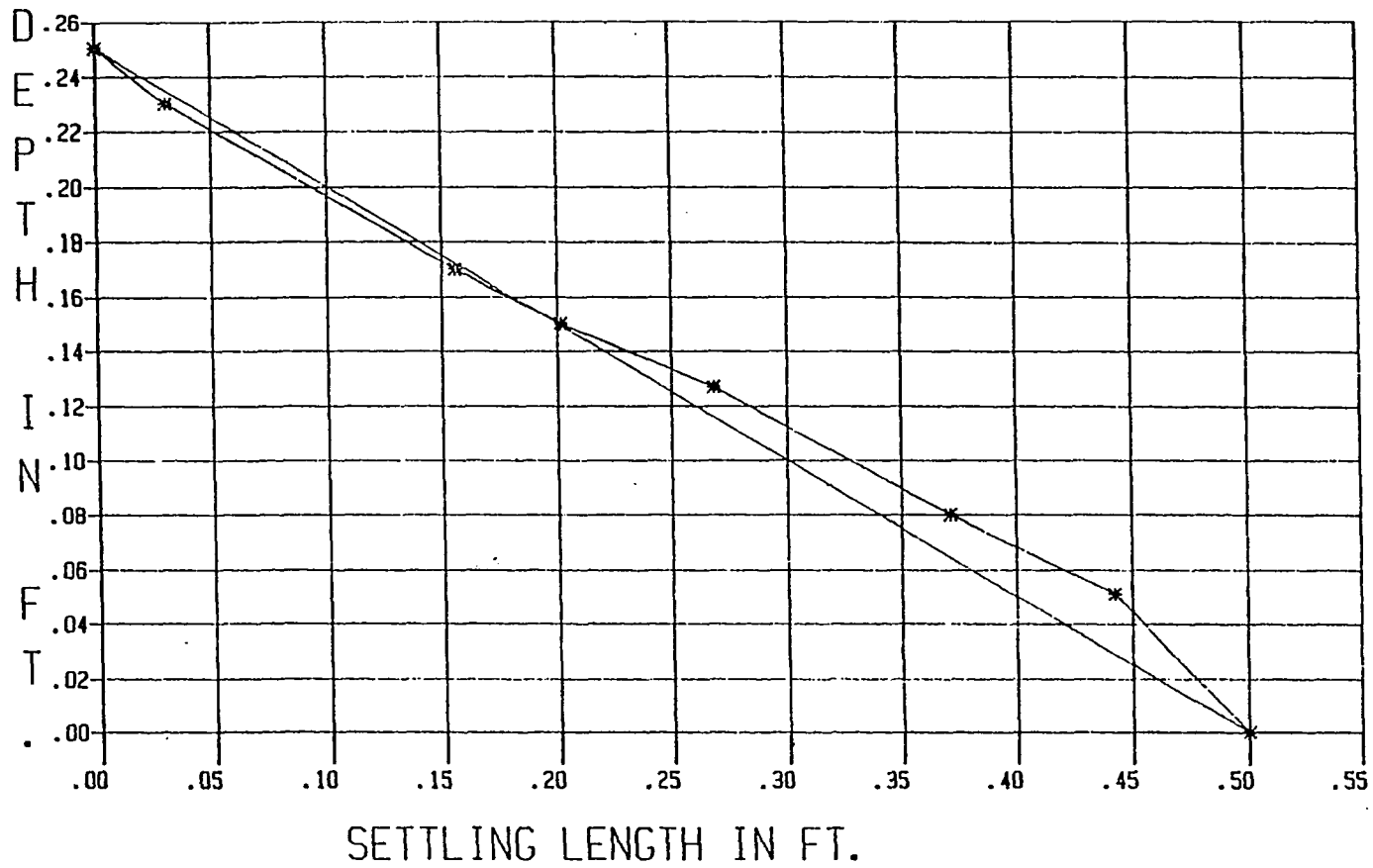

Figure 38. Particle trajectory for Example 1

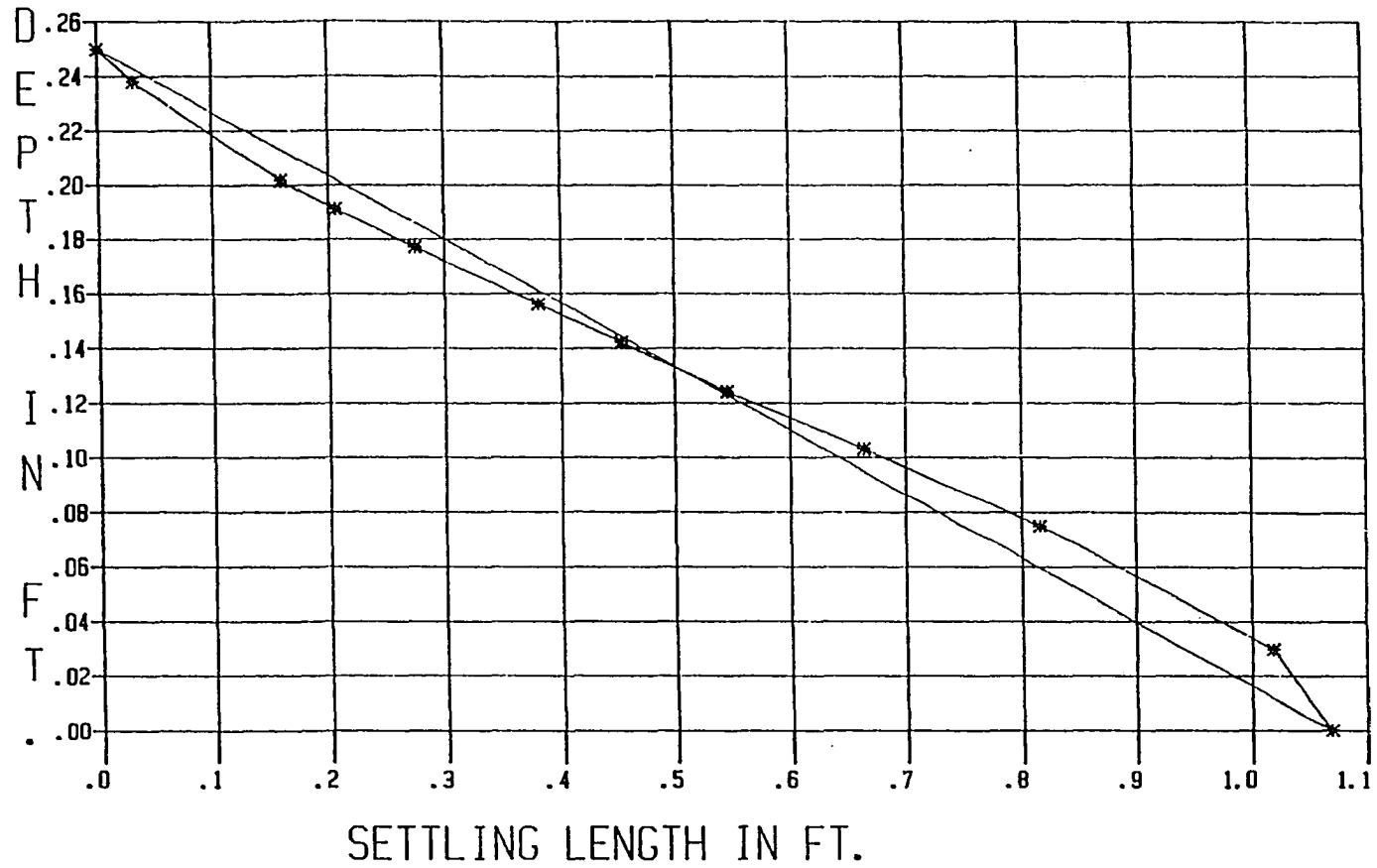

Figure 39. Particle trajectory for Example 2

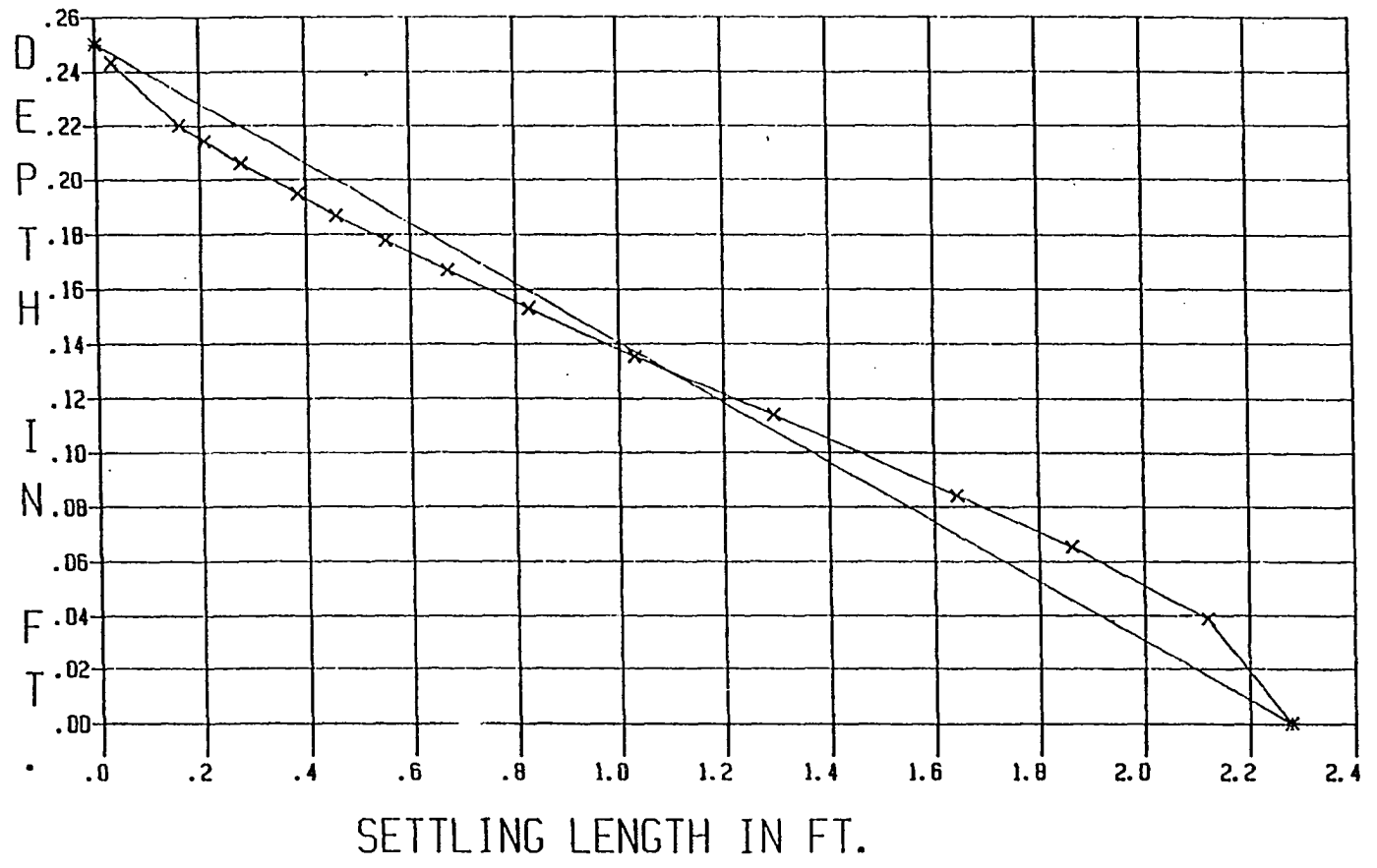

Figure 40. Particle trajectory for Example 3

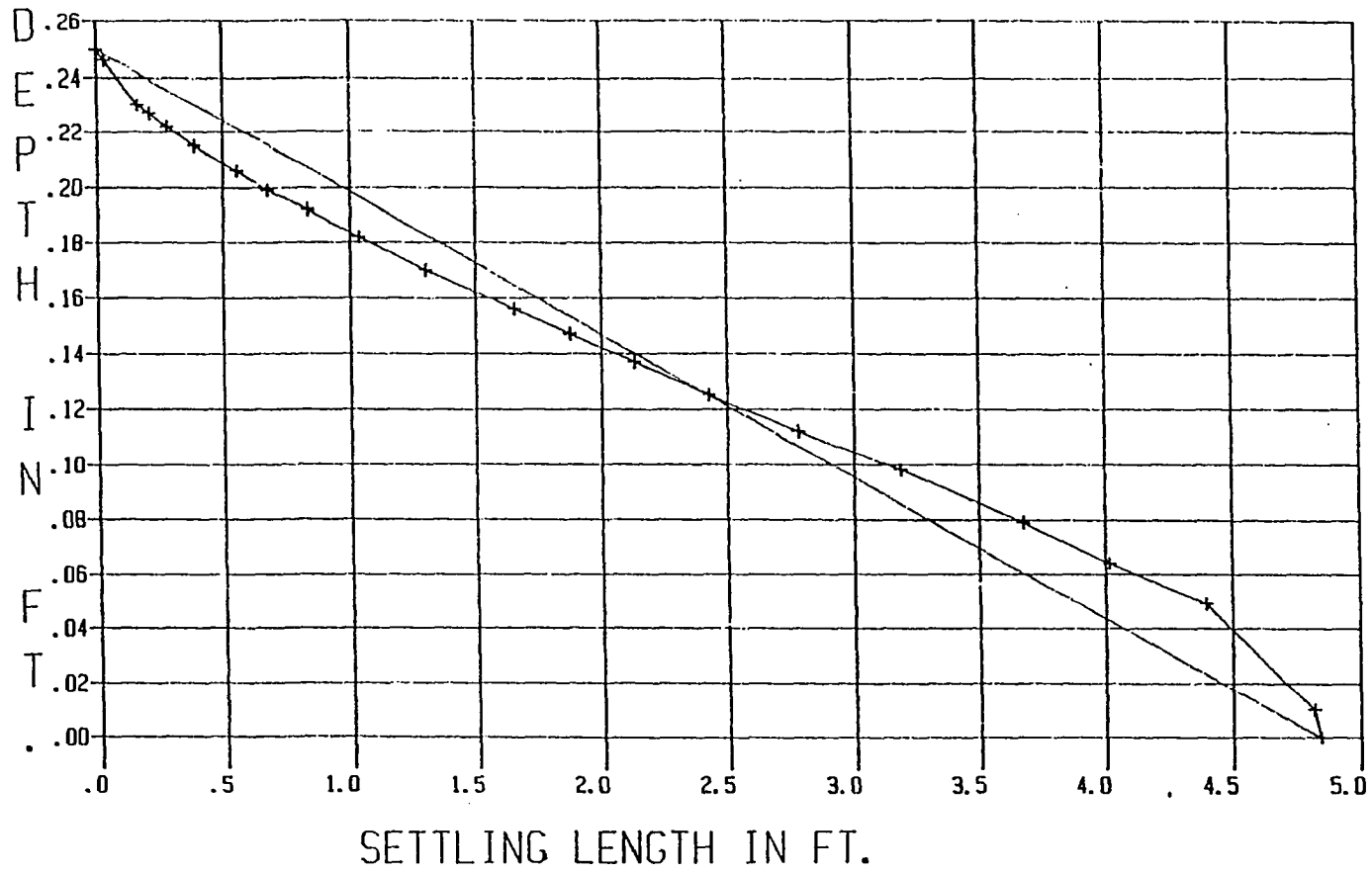

Figure 41. Particle trajectory for Example 4

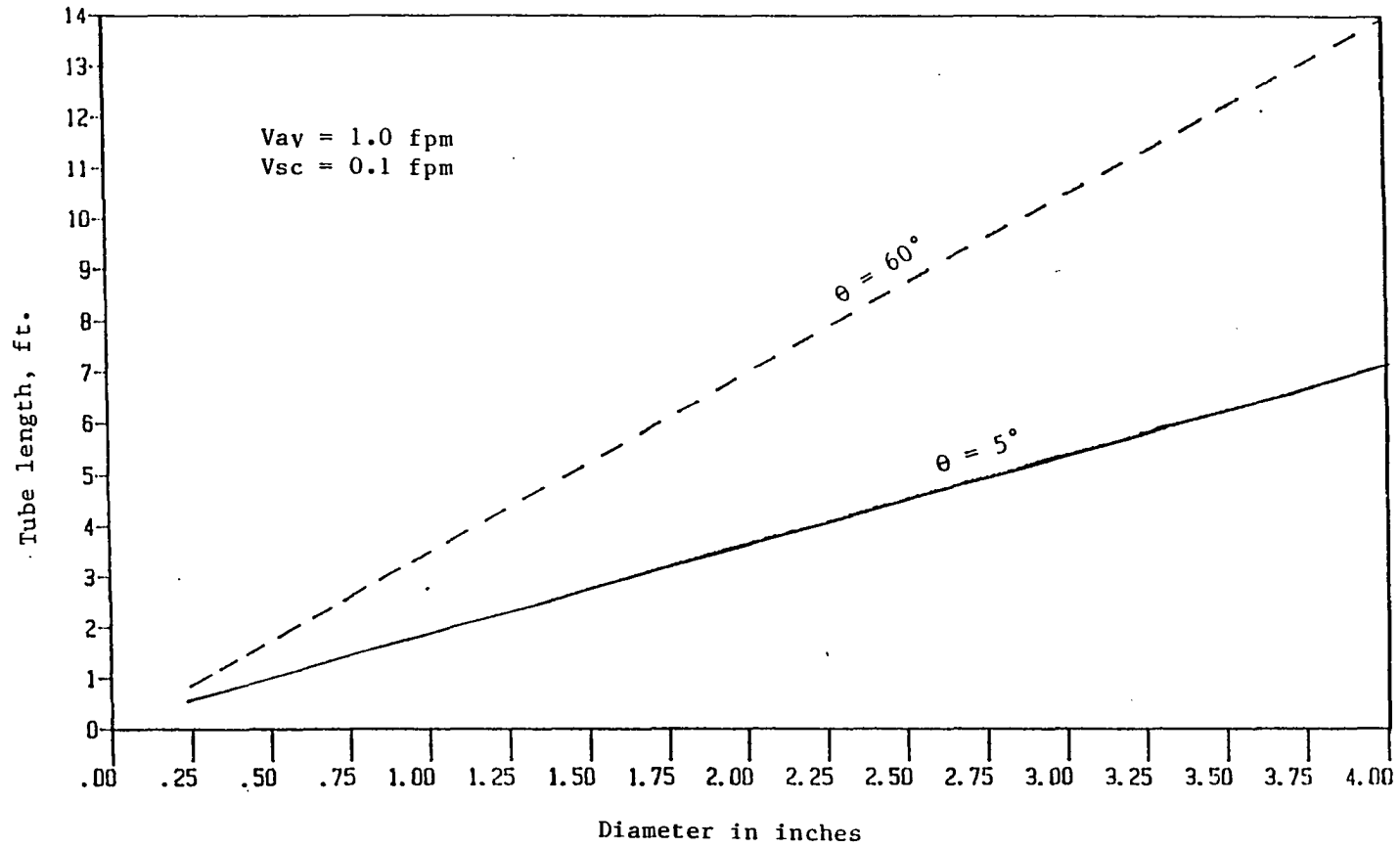

Figure 42. The effect of increasing tube diameter on the required tube length using Fadel's model

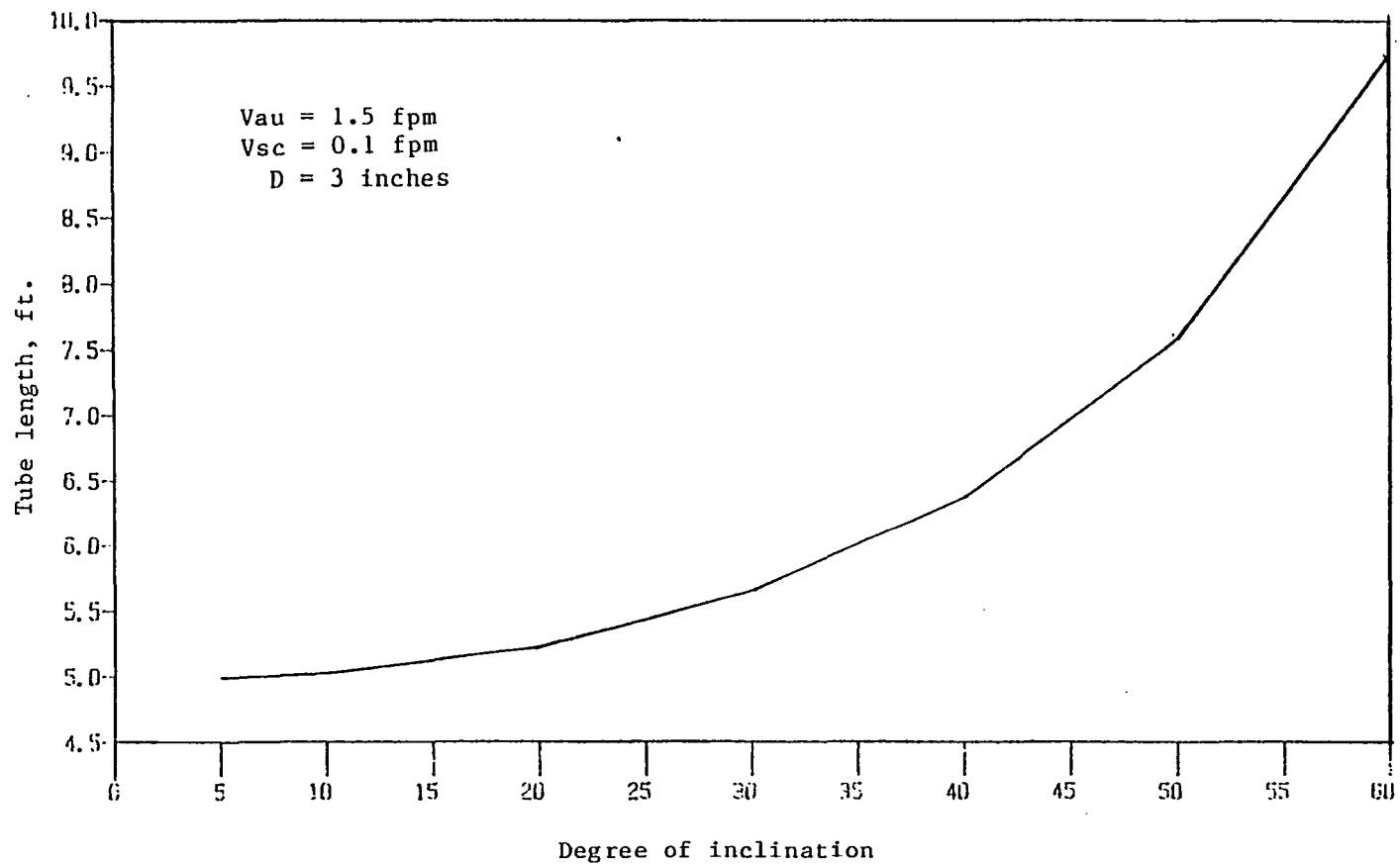

Figure 43. The effect of the degree of inclination on the required tube length using Fadel's model

3) Average flow velocity

Higher flow velocities require longer tubes. Figure 44 illustrates this effect.

4) Particle settling velocity

Lower particle settling velocities also require longer tubes. Figure 45 shows the effect of lowering the particle settling velocity on the required tube length.

5) Temperature

Temperature affects both fluid viscosity and the particle settling velocity. Changes in water temperature changes the distance between the velocity profiles. Figure 46 illustrates this effect on the required length, which is insignificant. The temperature effect on the particle velocity is the responsibility of the designer. In general, the lower the water temperature, the longer the required tube length.

Differences Between the Fadel Model and Yao and Culp Models

In order to explain the differences between the author's model and the other two models, the difference between the Yao and Culp et al.'s models should be first discussed.

Yao's Equation (13) may be rearranged as:

$$V_{sc} (\sin \theta + 1/D \cos \theta) = 1.33 V_{av} .$$

From this, it follows that:

$$V_{sc} \sin \theta + 1 (V_{sc} \cos \theta)/D = 1.33 V_{av}$$

and

$$1.33 V_{av} - V_{sc} \sin \theta = 1/d V_{sc} \cos \theta . \quad (23)$$

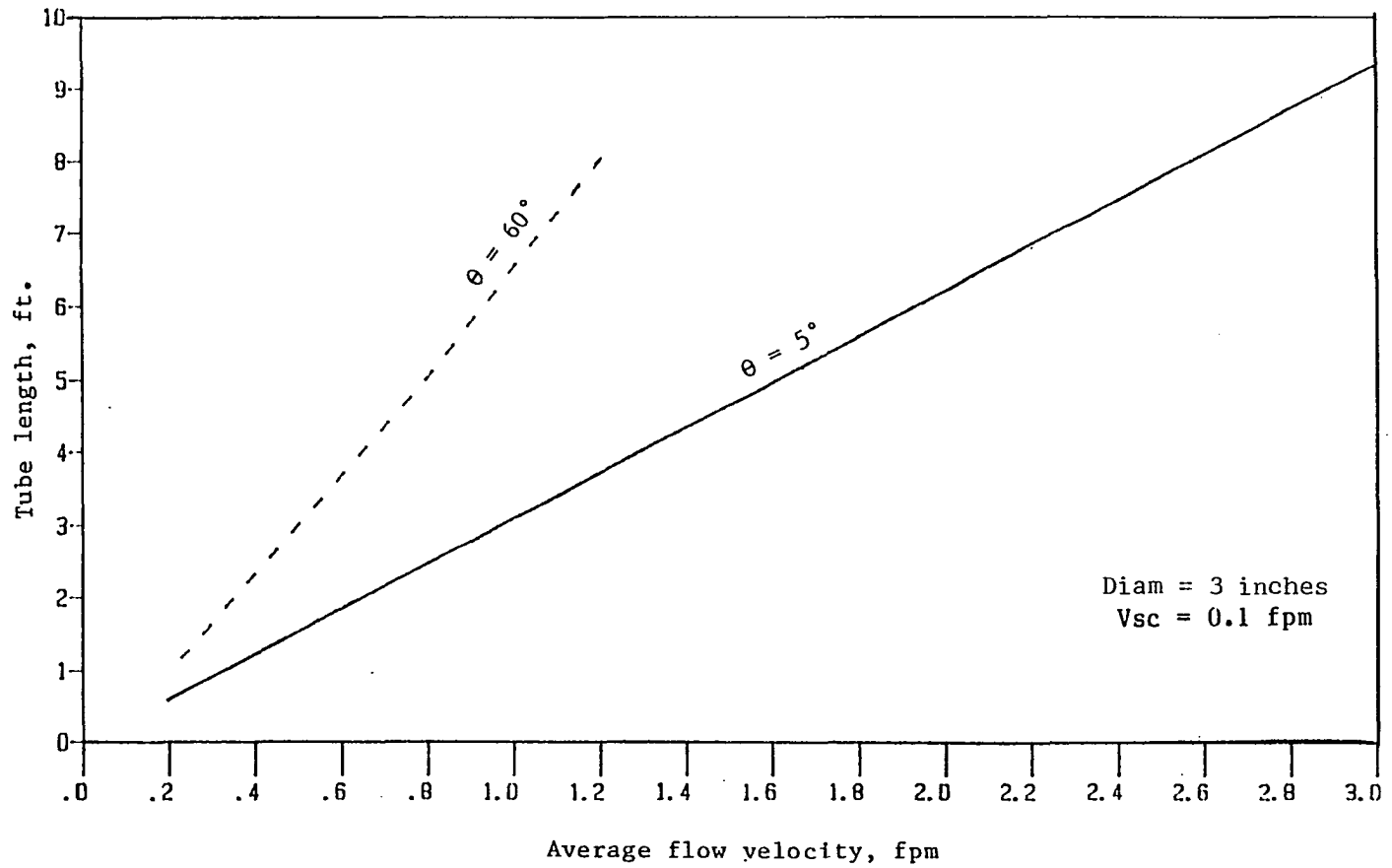

Figure 44. The effect of increasing the flow velocity on the required tube length using Fadel's model

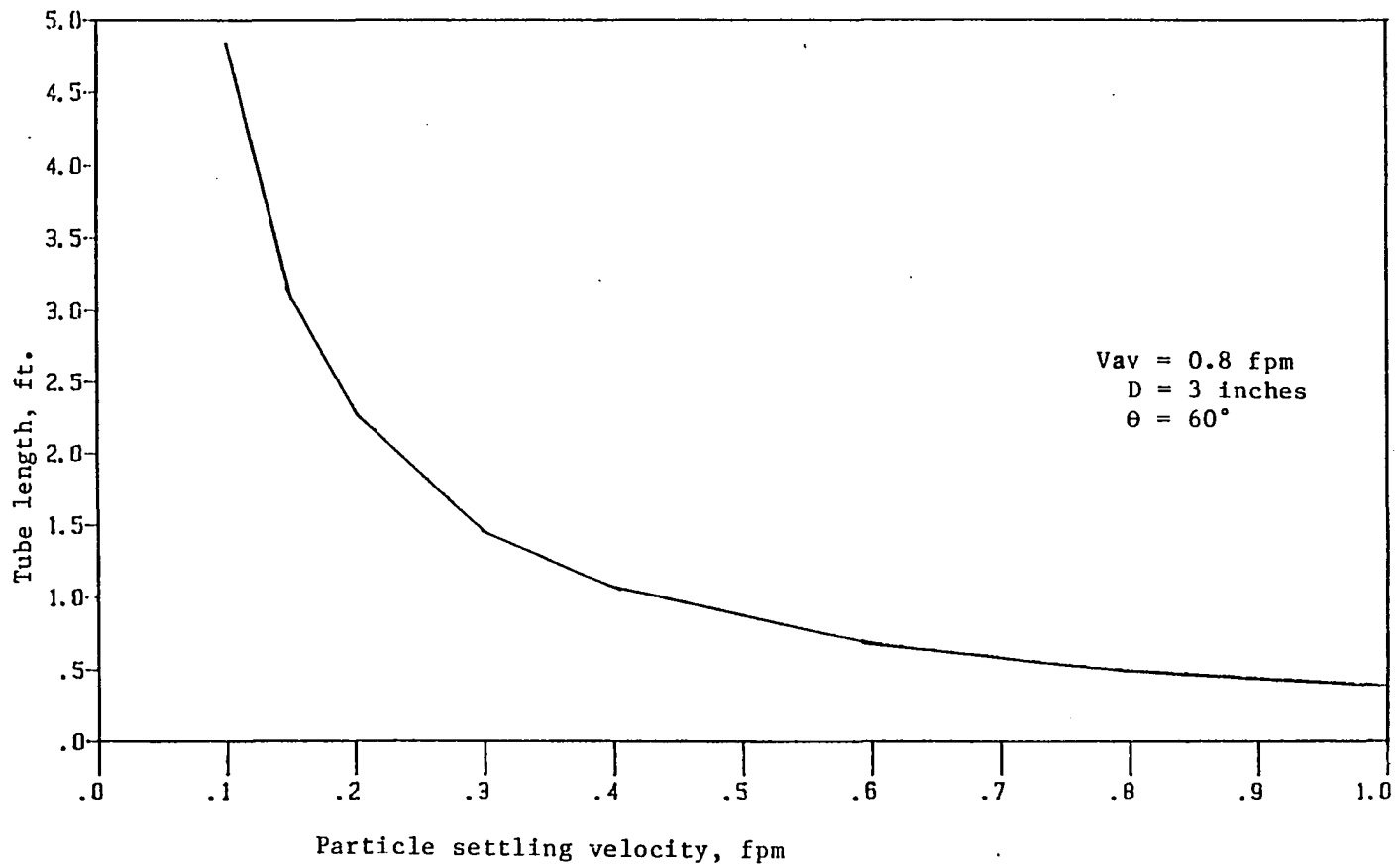

Figure 45. The effect of increasing the particle settling velocity on the required tube length using Fadel's model

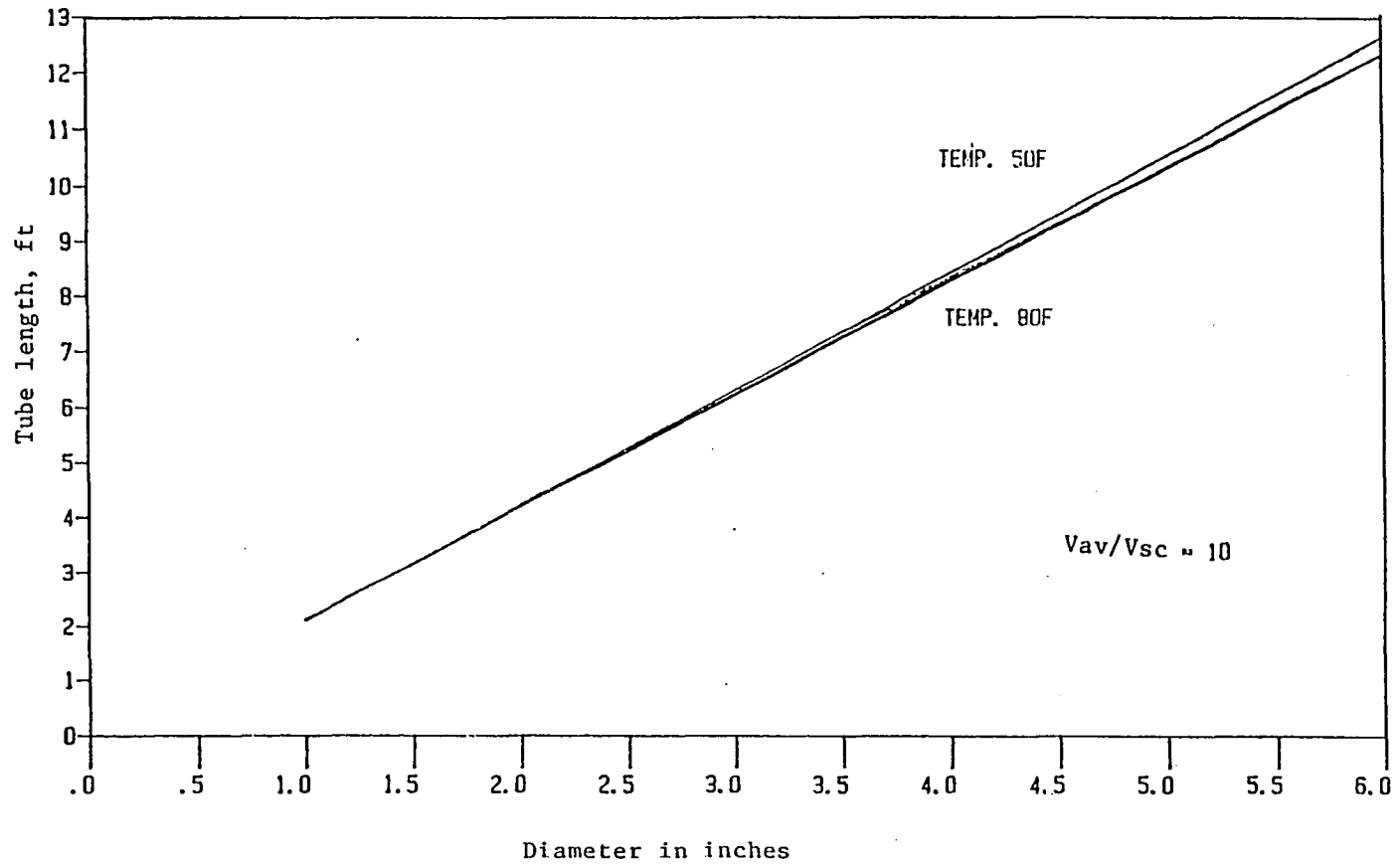

Figure 46. The effect of temperature increase on the required tube length using Fadel's model

When this is done, the following equation is obtained:

$$(1.33 V_{av} - V_{sc} \sin \theta)/l = (V_{sc} \cos \theta)/d \quad (24)$$

When one compares this equation with that equation obtained by Culp et al.,

$$(V_{av} - V_{sc} \sin \theta)/l = V_{sc} \cos \theta/d \quad (25)$$

it becomes apparent that the only difference between these two models is the constant 1.33 which is multiplied by V_{av} . This difference results from Yao's assumption of a parabolic velocity profile. The constant, 1.33, can be obtained simply by integrating the area under the parabolic velocity profile divided by the area under the uniform velocity profile, Figure 47. At θ equal zero, the difference between the length required by Yao's model is 1.33 times the length required by Culp et al. model. This is also true at 5 degrees of inclination. At angles greater than 5 degrees, the effect of $V_{sc} \sin \theta$ will be significant at low V_{av} to V_{sc} ratios, but insignificant at higher V_{av} to V_{sc} ratios. Figure 48 compares Yao's ratio of required length to Culp et al. calculated length for 60 degree tubes.

The model proposed herein can be expressed in the same way. The equation would be written as follows:

$$(n V_{av} - V_{sc} \sin \theta)/l = (V_{sc} \cos \theta)/d \quad (26)$$

where "n" is a variable whose value depends on the number of velocity profiles used to calculate the required tube length. The value of "n" represents the average of the areas under these velocity profiles divided

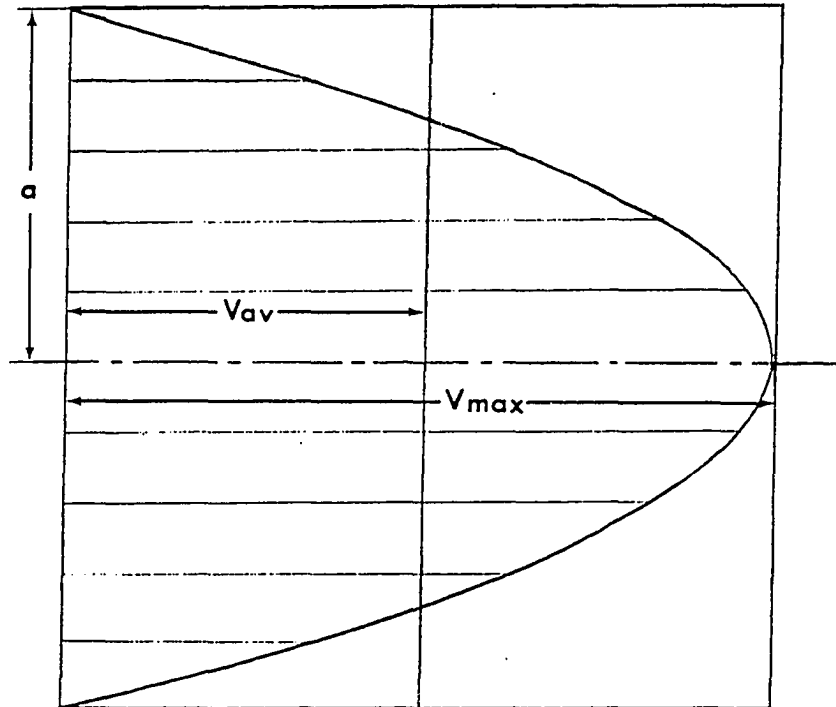

Figure 47. Yao's shape factor equals the area under the parabolic velocity profile divided by the area under the uniform velocity profile

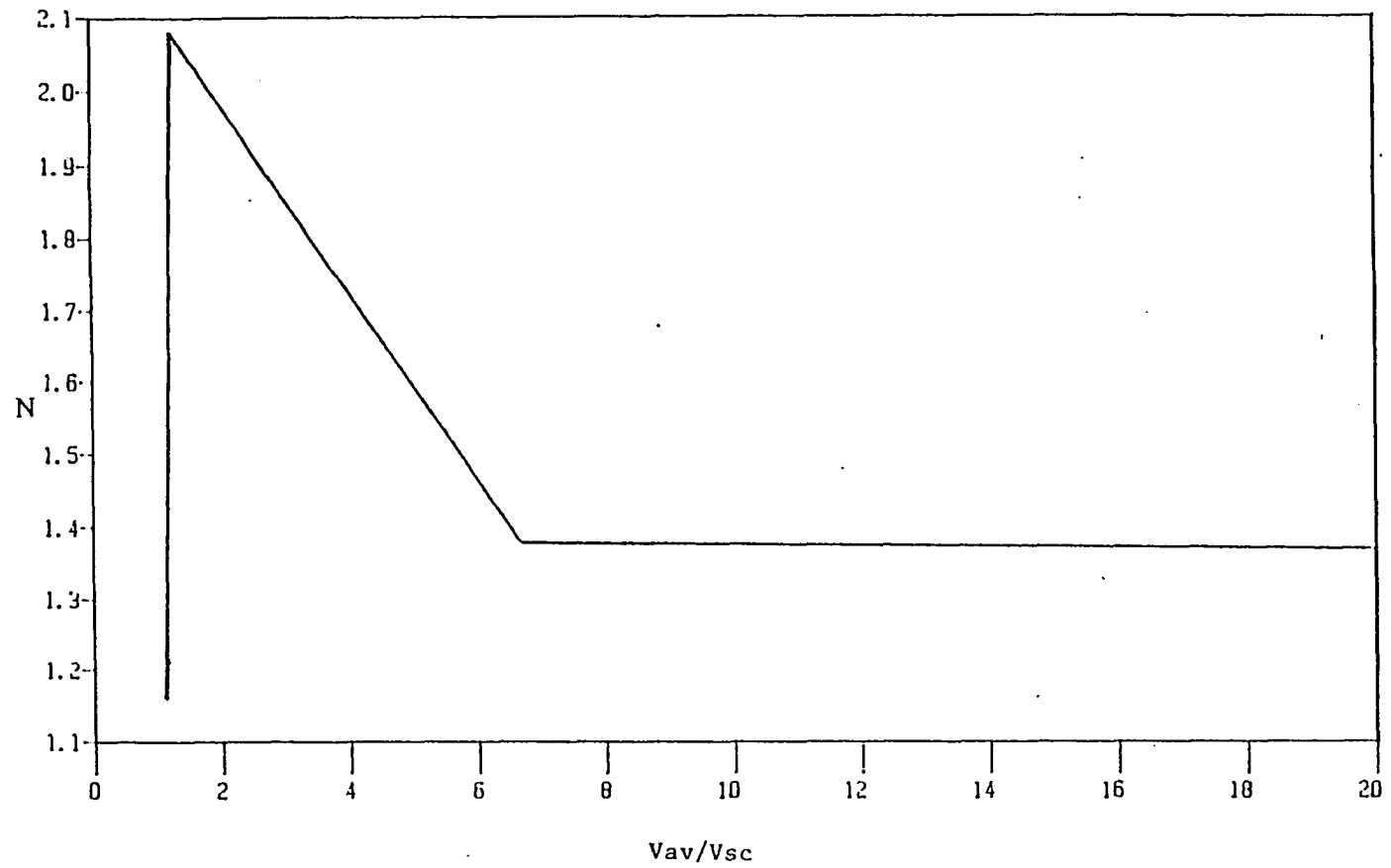

Figure 48. The ratio of the required length by Yao to Culp's calculated length for 60° tubes

by the area under the uniform velocity. The "n" value can be calculated simply by assuming an angle of inclination equal to zero, which yields the following:

$$n \text{ Vav}/l = \text{Vsc}/D \quad (27)$$

and

$$L \text{ (suggested)} = L' = n\text{Vav} D/\text{Vsc} . \quad (28)$$

Dividing L' by the length calculated by Culp et al. ($L = \text{Vav} D/\text{Vsc}$), the value of "n" will equal to L'/L , i.e., $n = L'/L$.

Method of Using the Model

Three methods have been devised to use this model.

a) Computer program

To use the Fadel model most effectively, tube designers should have a copy of the author's computer program. While this method would provide the most accurate tube design results, the program is not yet available commercially.

b) Design charts

Design charts have been developed from successive computer solutions which allow the designer to obtain the required length for different tube diameters, average flow velocities, particle settling velocities, degrees of inclination and water temperatures. Figures 49, 50, 51, 52, and 53, are design charts for the most practical tube diameters, tube diameters of 2, 3, 4, 5, and 6 inches. The abscissa of the charts represents the ratio of the average flow velocity to the design particle settling velocity, Vav to Vsc . As long as the ratio remains constant, the same

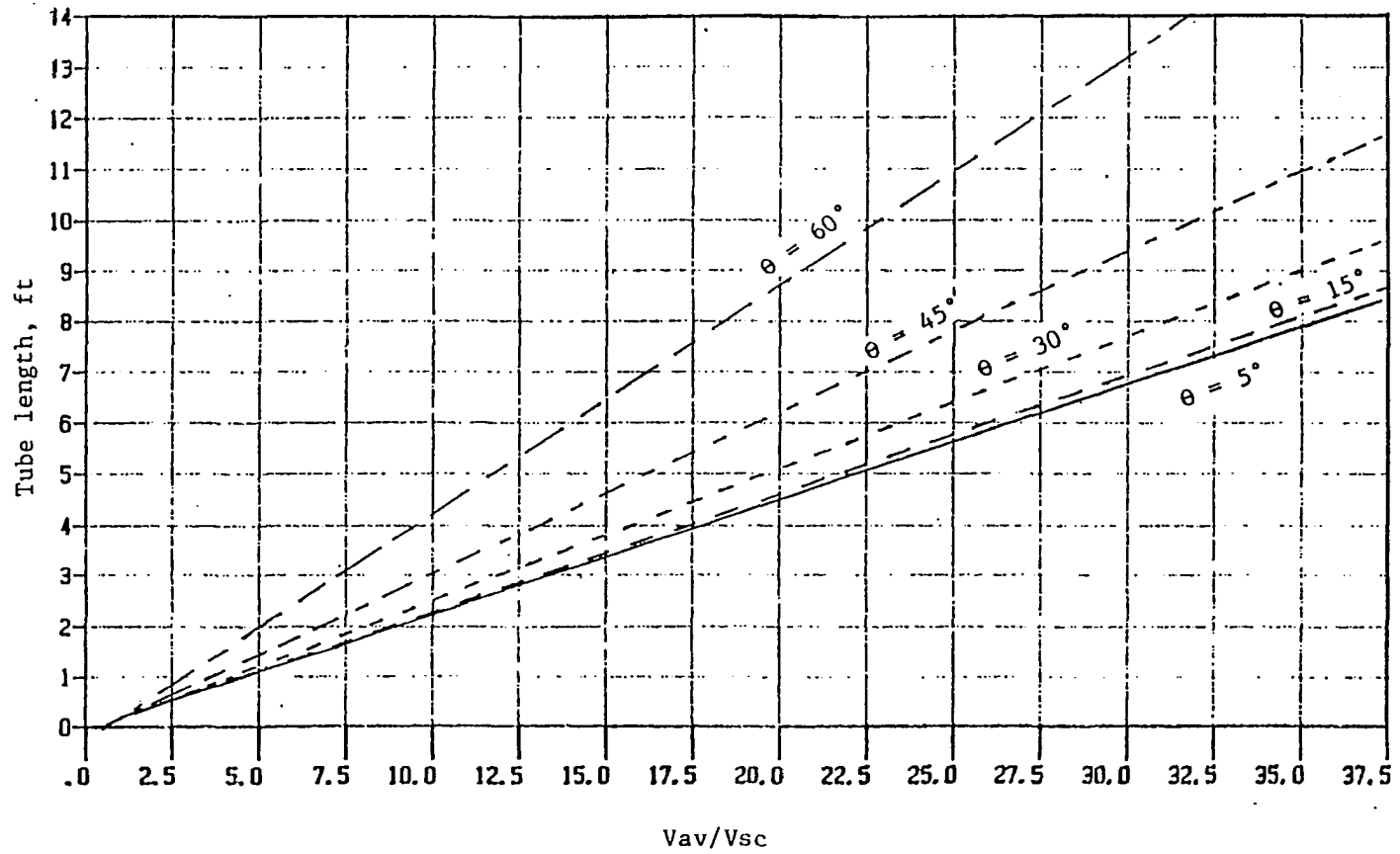

Figure 49. The design chart for 2" diameter tubes

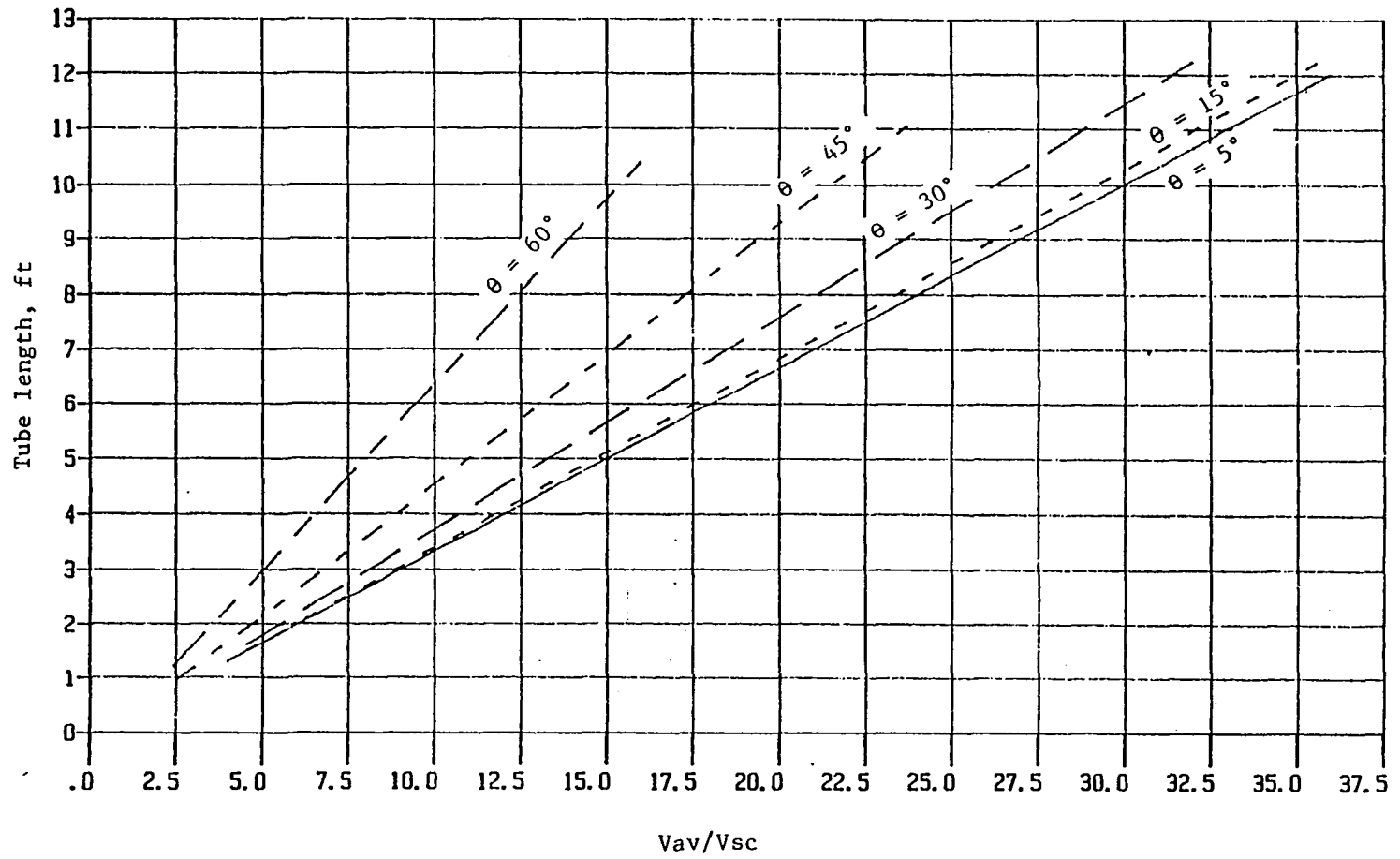

Figure 50. The design chart for 3" diameter tubes

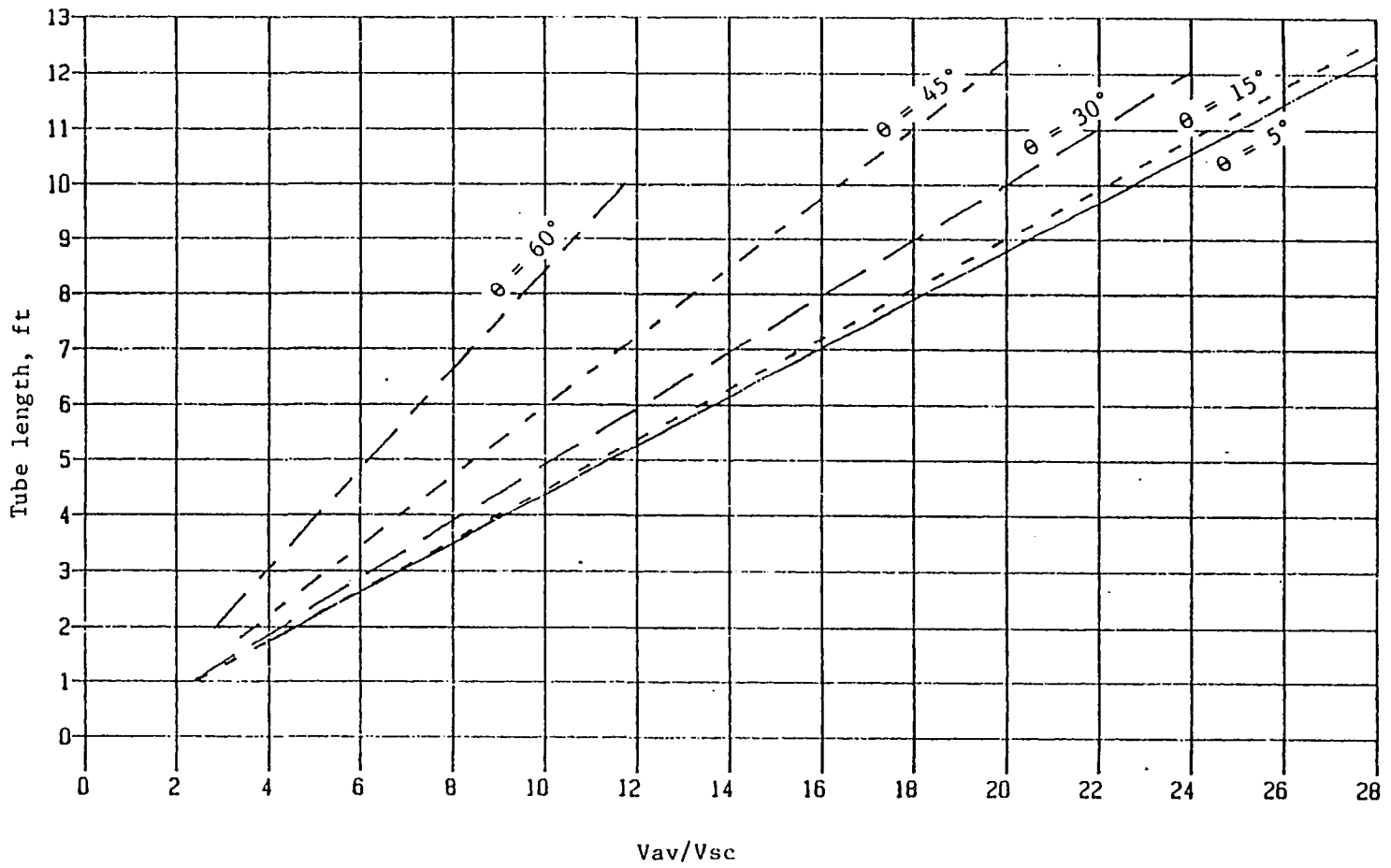

Figure 51. The design chart for 4" diameter tubes

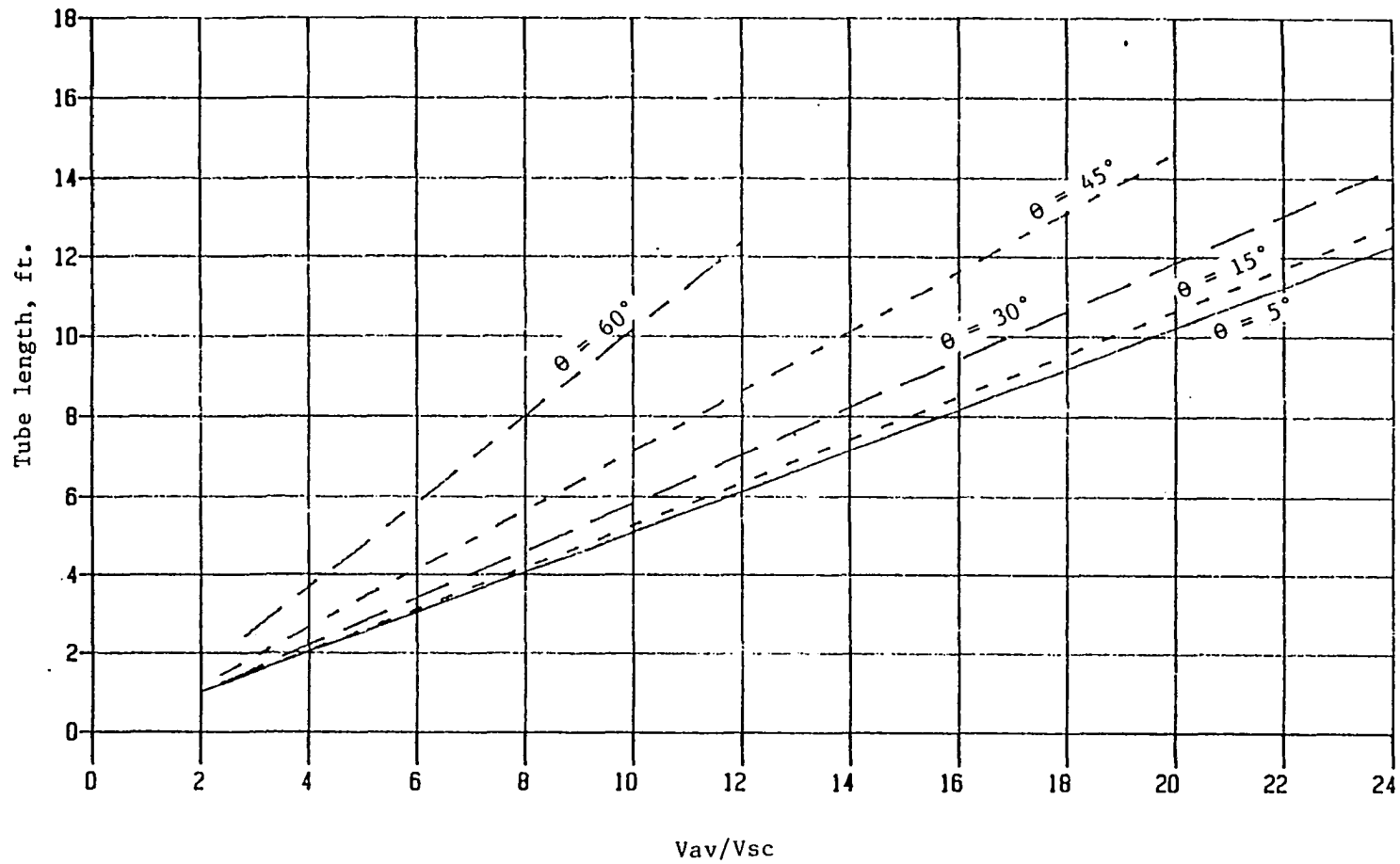

Figure 52. The design chart for 5" diameter tubes

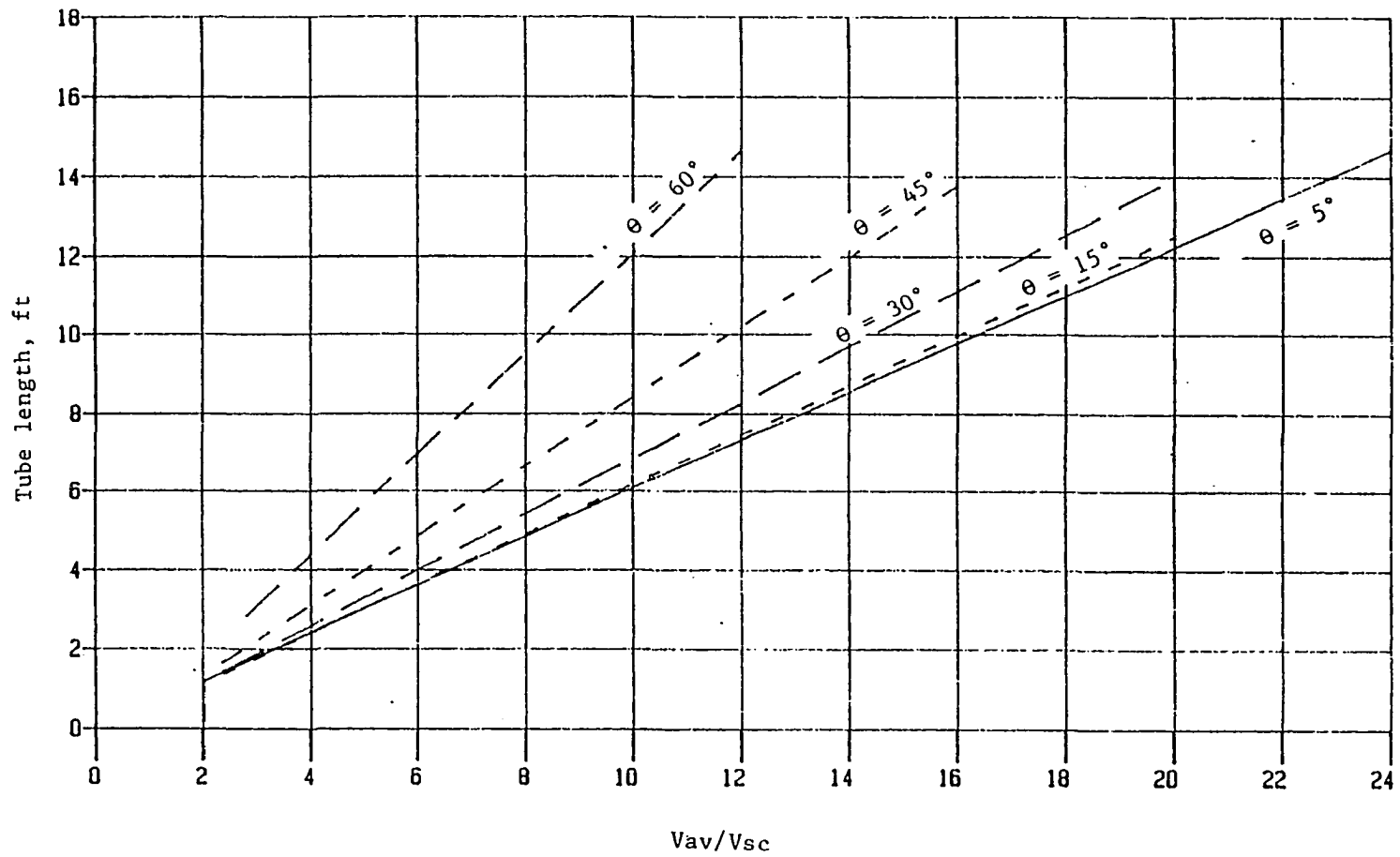

Figure 53. The design chart for 6" diameter tubes

tube lengths will be obtained regardless of their numerical values. The ratio of V_{av} to V_{sc} is limited by a maximum value of V_{av} assigned on the basis of the maximum Reynolds numbers associated with laminar flow conditions in the tubes. Based on the tube hydraulic radius, the maximum Reynolds number is 500, as recommended in the literature.

The designer using these charts should first establish a value for the following parameters to be evaluated in tube design:

- 1) Angle of inclination,
- 2) Tube diameter,
- 3) Average flow velocity,
- 4) Minimum expected particle settling velocity, and
- 5) Water temperature range.

When these parameter values are known, the designer selects the chart for the selected tube diameter and calculates the ratio of V_{av} to V_{sc} , plugging these values and the degree of tube inclination into the design chart to obtain the required tube length. Particles having a settling velocity higher than the chosen values will settle in lengths shorter than the required length indicated on the chart.

3) Empirical equation

The only unknown in the suggested Eq. 26 is the value of n , which varies from 1 at very V_{av}/V_{sc} low ratios to 1.4 at high ratios. The value of n can be determined from the following empirical equation:

$$n = 0.2 \log \left(\frac{V_{av} - V_{sc} \sin \theta}{V_{sc} \cos \theta} \right) + 1.05 \quad (29)$$

Knowing n , the required length can be determined from Eq. 26.

The empirical equation was found by:

1) Assuming θ equal to zero; in this case the required length for the V_{av}/V_{sc} ratio range of 1 to 25 at 80°F temperature was obtained by using the computer program for diameters of 2 to 6 inches.

2) Dividing the designing length by the calculated length from Culp et al. equation; the corresponding n values are then obtained.

3) Drawing the relationship between n and the ratio V_{av}/V_{sc} ; in using the curve fitting technique for this step, the following equations were obtained for diameters of 2 to 6 inches:

For: diameter = 2 inches

$$n = 0.085 \ln \left(\frac{V_{av} - V_{sc} \sin\theta}{V_{sc} \cos\theta} \right) + 1.055$$

diameter = 3 inches

$$n = 0.082 \ln \left(\frac{V_{av} - V_{sc} \sin\theta}{V_{sc} \cos\theta} \right) + 1.089$$

diameter = 4 inches

$$n = 0.092 \ln \left(\frac{V_{av} - V_{sc} \sin\theta}{V_{sc} \cos\theta} \right) + 1.039$$

diameter = 5 inches

$$n = 0.091 \ln \left(\frac{V_{av} - V_{sc} \sin\theta}{V_{sc} \cos\theta} \right) + 1.022$$

diameter = 6 inches

$$n = 0.086 \ln \left(\frac{V_{av} - V_{sc} \sin\theta}{V_{sc} \cos\theta} \right) + 1.024$$

4) By averaging the constants in the five equations above, the following equation was obtained:

$$n = 0.087 \ln \left(\frac{V_{av} - V_{sc} \sin \theta}{V_{sc} \cos \theta} \right) + 1.046 .$$

5) By changing the ln term to a log term, Eq. 29 was obtained.

The equation gives a value of "n" with an accuracy of + or - 0.04 of the "n" value calculated by the computer program. Figures 54, 55, 56, 57, and 58 illustrate the above procedure. Figure 59 shows the effect of temperature on the value of "n" which is shown to be in the range of 0.03 at the maximum practical V_{av}/V_{sc} ratio of 25.

As a factor of safety, the following modified equation is desirable:

$$n = 0.2 \log \left(\frac{V_{av} - V_{sc} \sin \theta}{V_{sc} \cos \theta} \right) + 1.10 . \quad (30)$$

Essentially Horizontal Tubes

To simplify the study of the effect of suspended solids accumulation on the bottom of an essentially horizontal tube, the following assumptions are necessary:

- 1) Solids accumulation on the inside bottom of the tube is uniformly distributed.
- 2) The tube cross-sectional area remaining after the area occupied by the solids is subtracted will be treated a circular tube having a new diameter equal to its free depth.
- 3) The velocity of flow in the solids-free area (the free area is the area calculated by subtracting the area of the sector occupied by the solids from the tube total cross section area) will equal the discharge divide by the solids-free area.

Tables 5 and 6 represent variations in the required tube length,

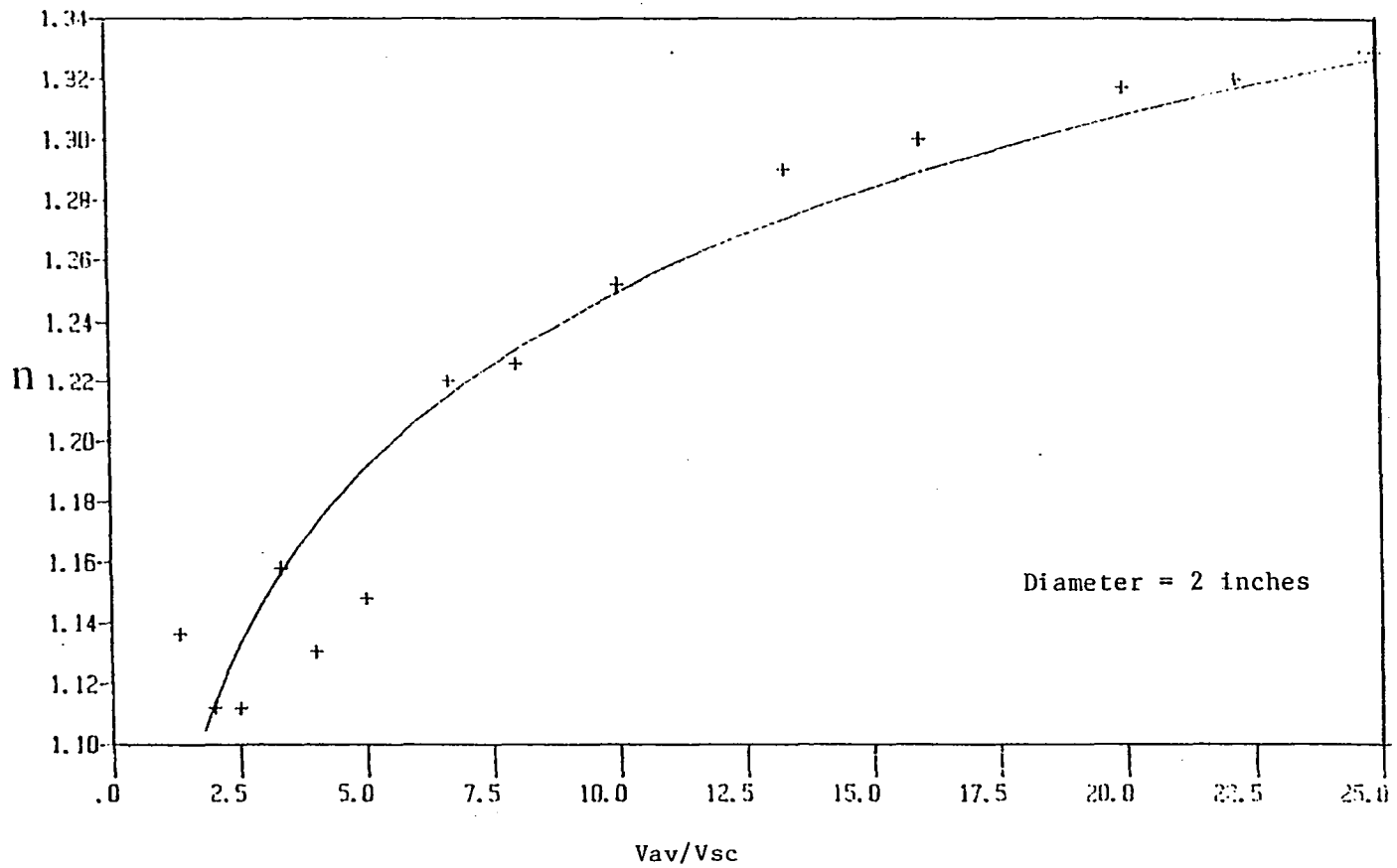

Figure 54. "n" versus Vav/Vsc for 2" diameter tube

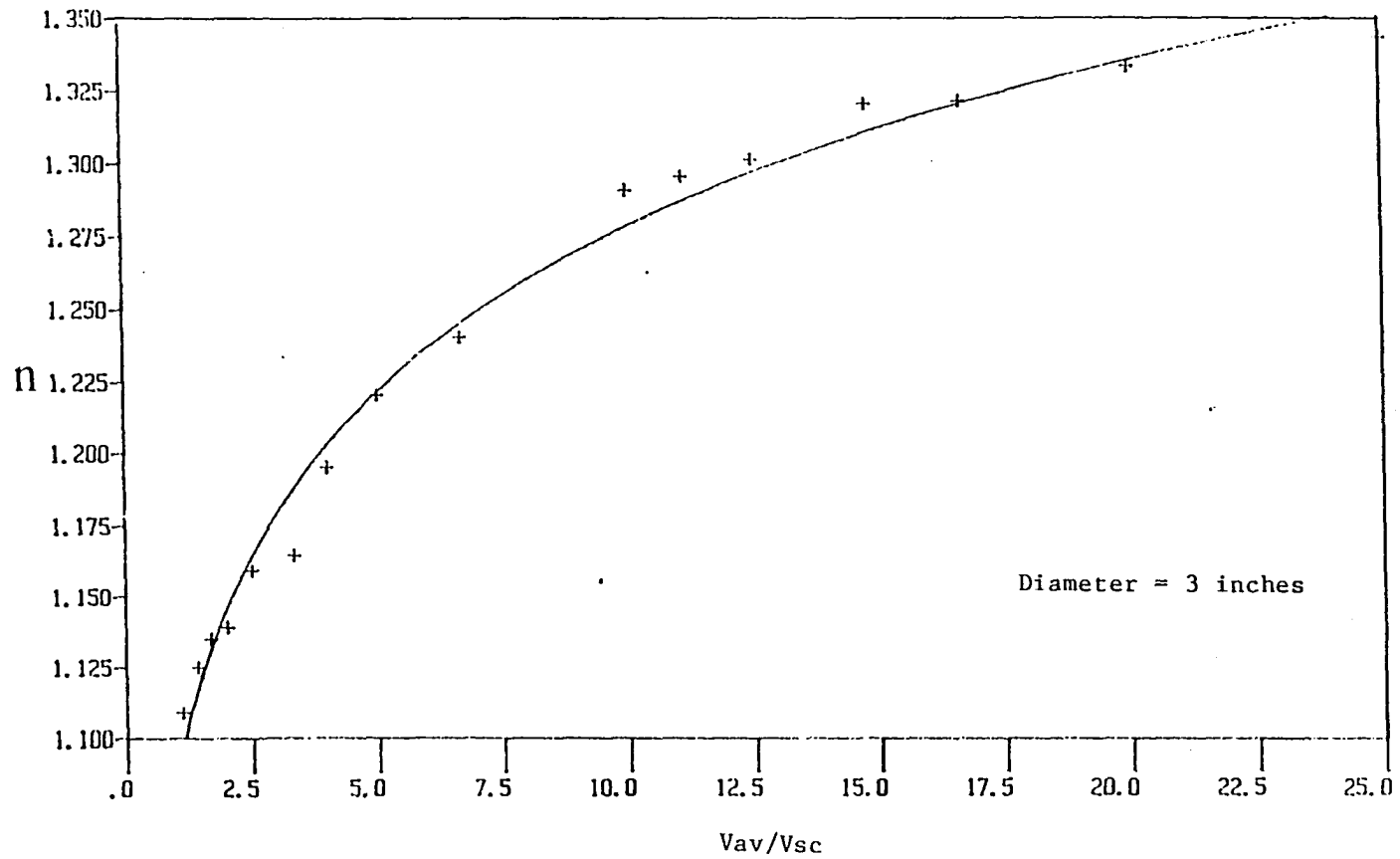

Figure 55. "n" versus V_{av}/V_{sc} for 3" diameter tube

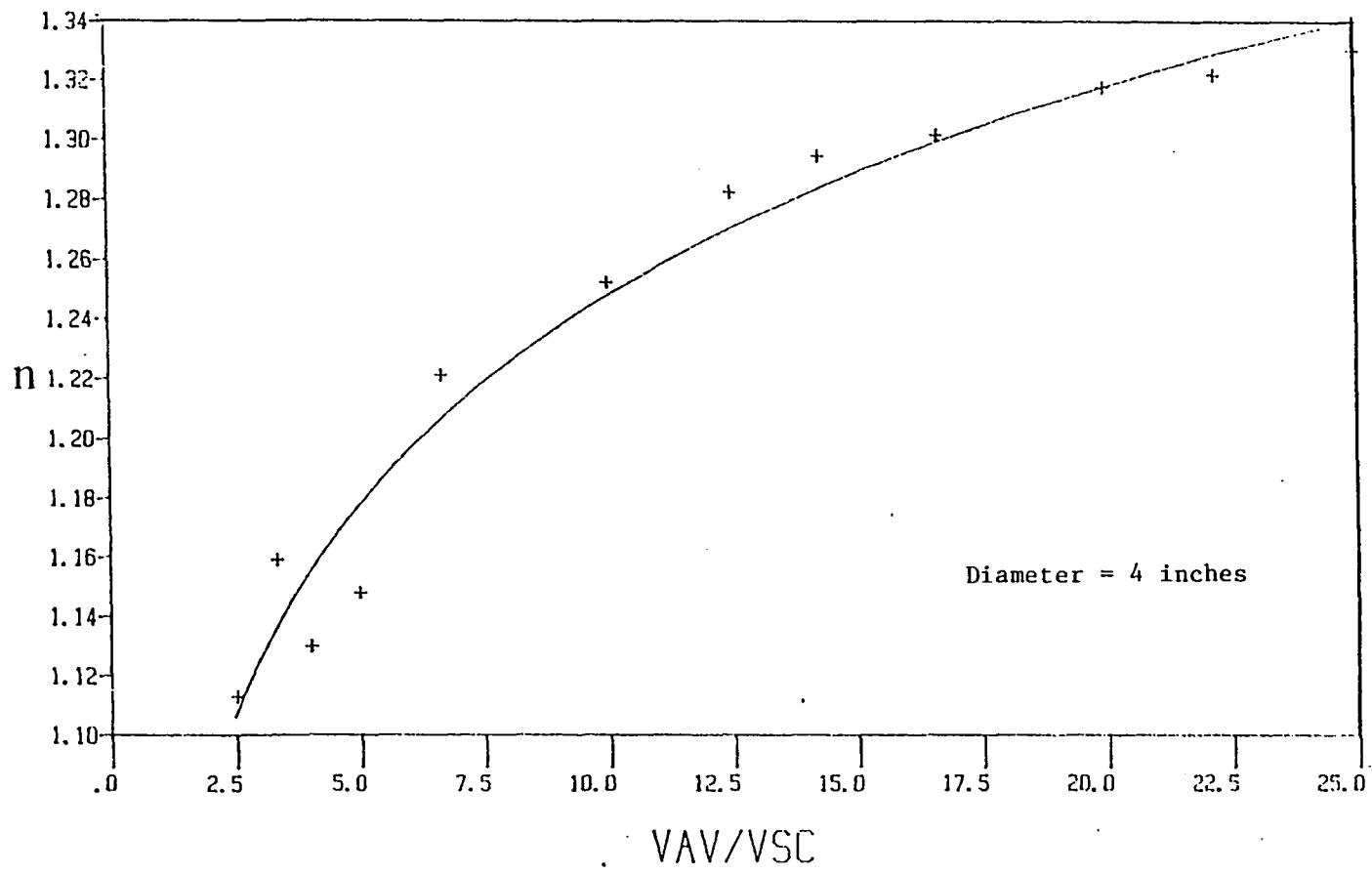

Figure 56. "n" versus Vav/Vsc for 4" diameter tube

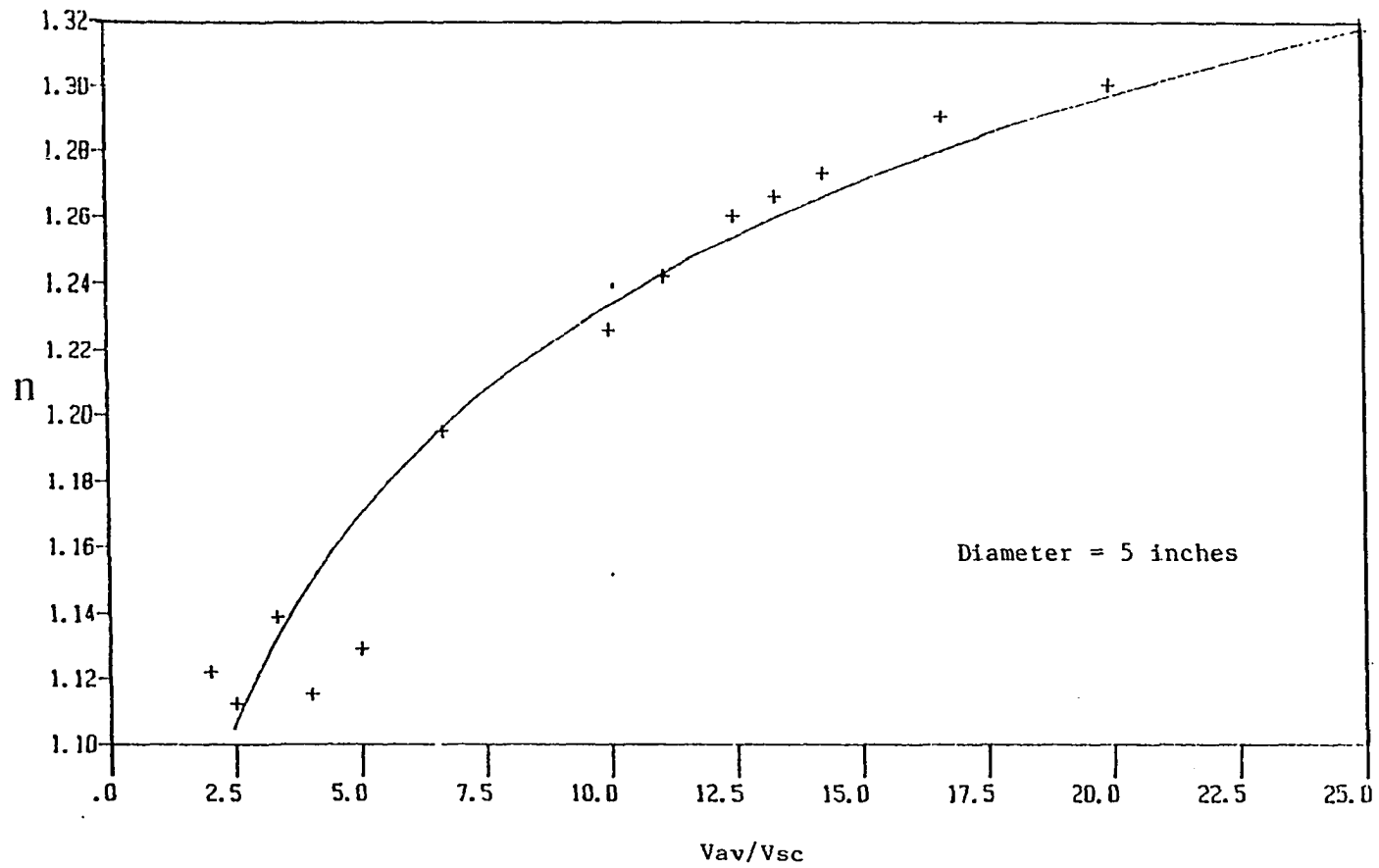

Figure 57. "n" versus Vav/Vsc for 5" diameter tube

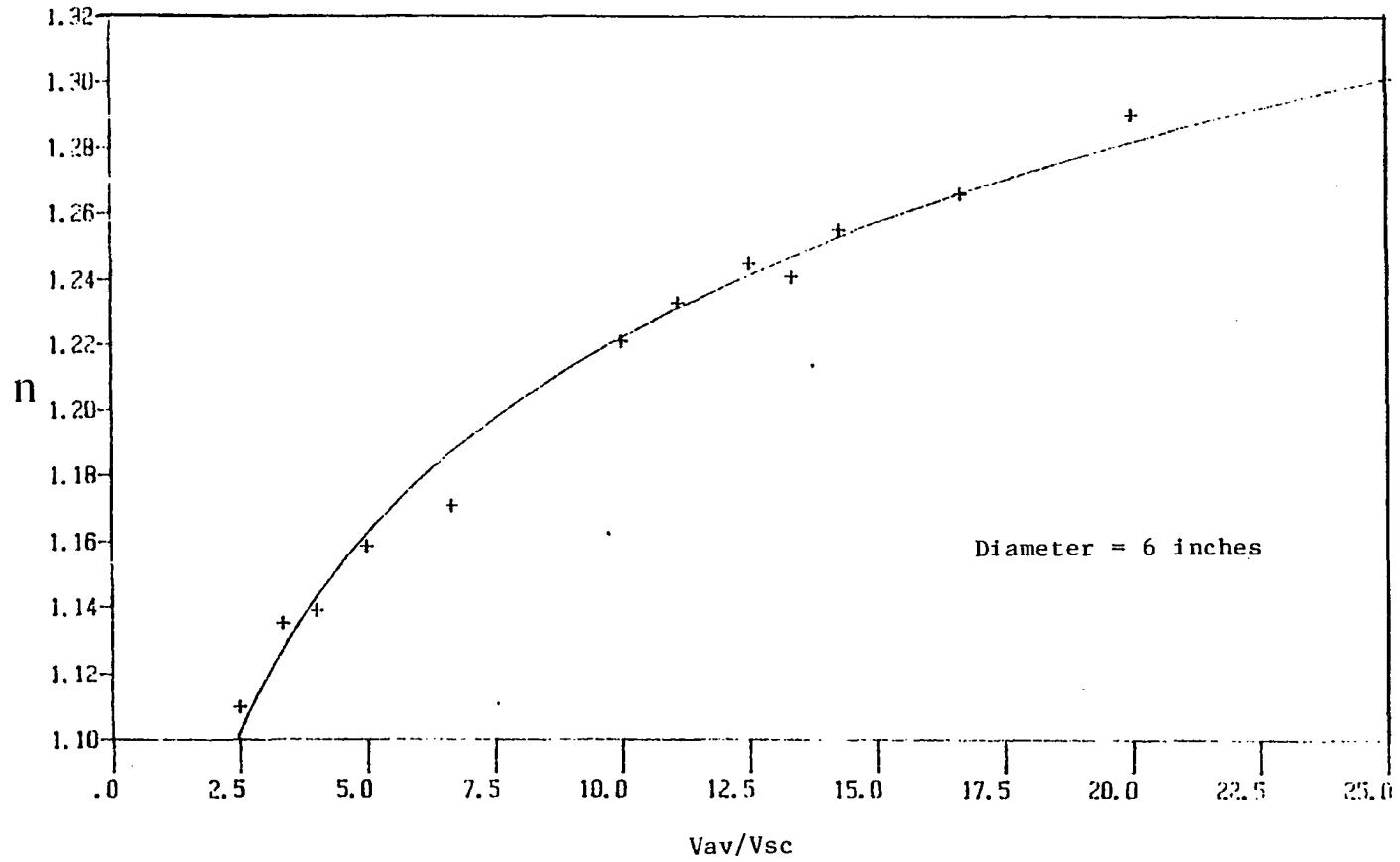

Figure 58. "n" versus V_{av}/V_{sc} for 6" diameter tube

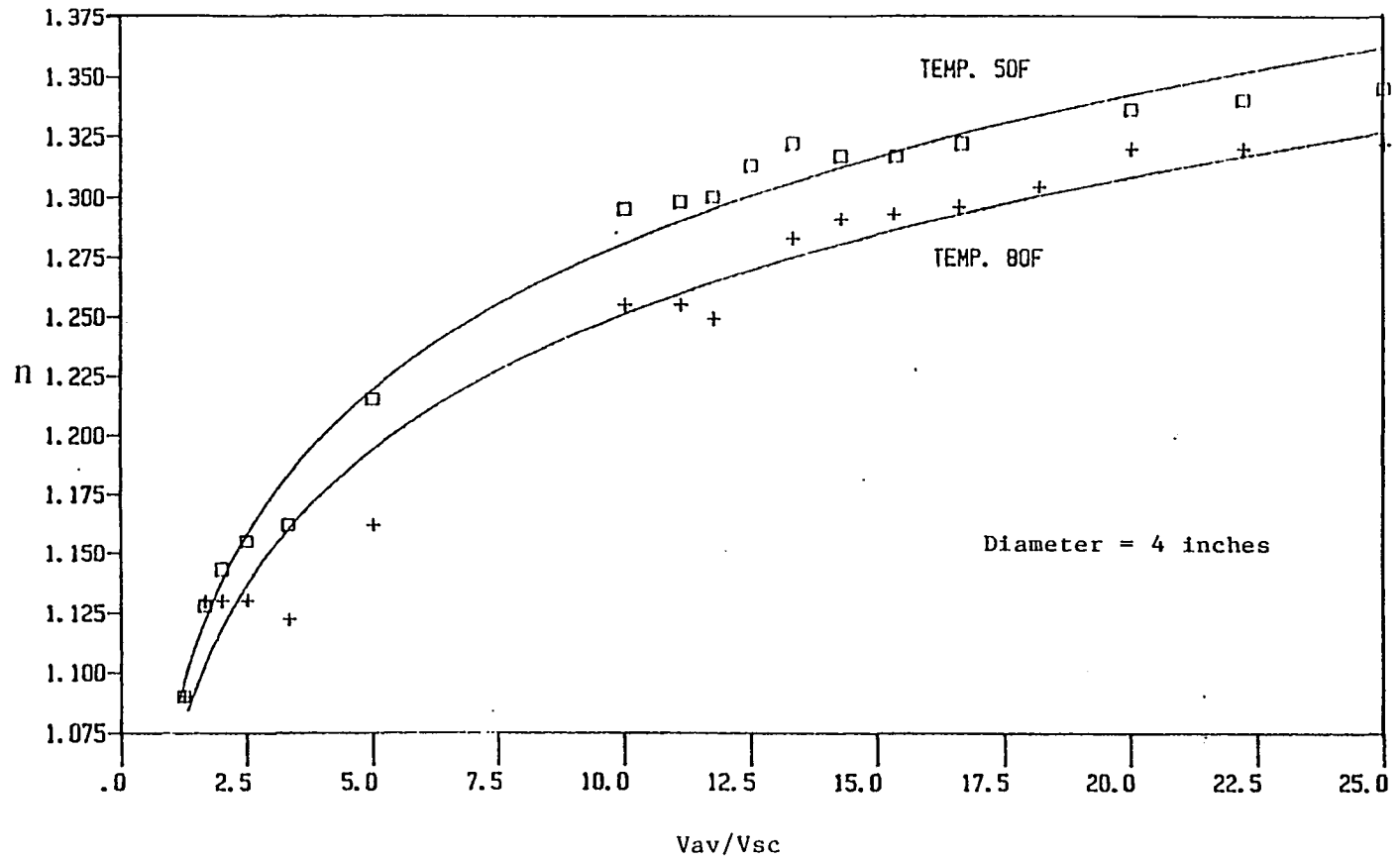

Figure 59. Temperature effect on the "n" value

Table 5. The effect of sludge accumulation on the required tube length for a 3" tube, settling velocity = 0.1 fpm, and degree of inclination = 5.0°

Solids-free depth (in)	Flow velocity (fpm)	Settl. length (ft)
3.00	1.00	3.223
2.25	1.24	3.055
2.00	1.36	2.984
1.50	2.00	3.334
1.00	3.40	3.831
0.75	5.00	4.240

Table 6. The effect of sludge accumulation on the required tube length for the 4" tube settling velocity = 0.1 fpm, and degree of inclination = 5.0°

Solids-free depth (in)	Flow velocity (fpm)	Settl. length (ft)
4.00	1.00	4.165
3.50	1.08	3.990
3.00	1.24	4.007
2.50	1.52	4.116
2.00	2.00	4.395
1.50	2.92	4.875
1.00	5.11	5.759

based on the above assumptions for two tubes with diameters of 3 and 4 inches, respectively.

Figures 60 and 61 illustrate the sludge accumulation effects presented in the above two tables, in which the required tube length decreases with solids accumulation until a certain depth is reached at which the length then increases with solids accumulation. The explanation for this behavior can be related to the geometrical distribution of the circular sections. When the tube fills with solids, residual tube depth diminishes more rapidly than the tube solids-free area, meaning that the depth through which the particle settles decreases faster than the flow velocity increases. This condition favors decreasing the required settling length until the point is reached when small changes in diameter lead to large decreases in the solids-free area and significant increases in flow velocity. This condition is approached when the solids deposited approach close to the center of the circular tube. This leads to an increase in the required settling length.

If experimental work is consistent with this situation, the designer may use any of the above methods to design an essentially horizontal tube, with the provision that periodic backflushing must be performed when the tube is approximately 40% full. If the above situation is inconsistent with the experimental work, the recommended design should be established according to the results of the experimental work.

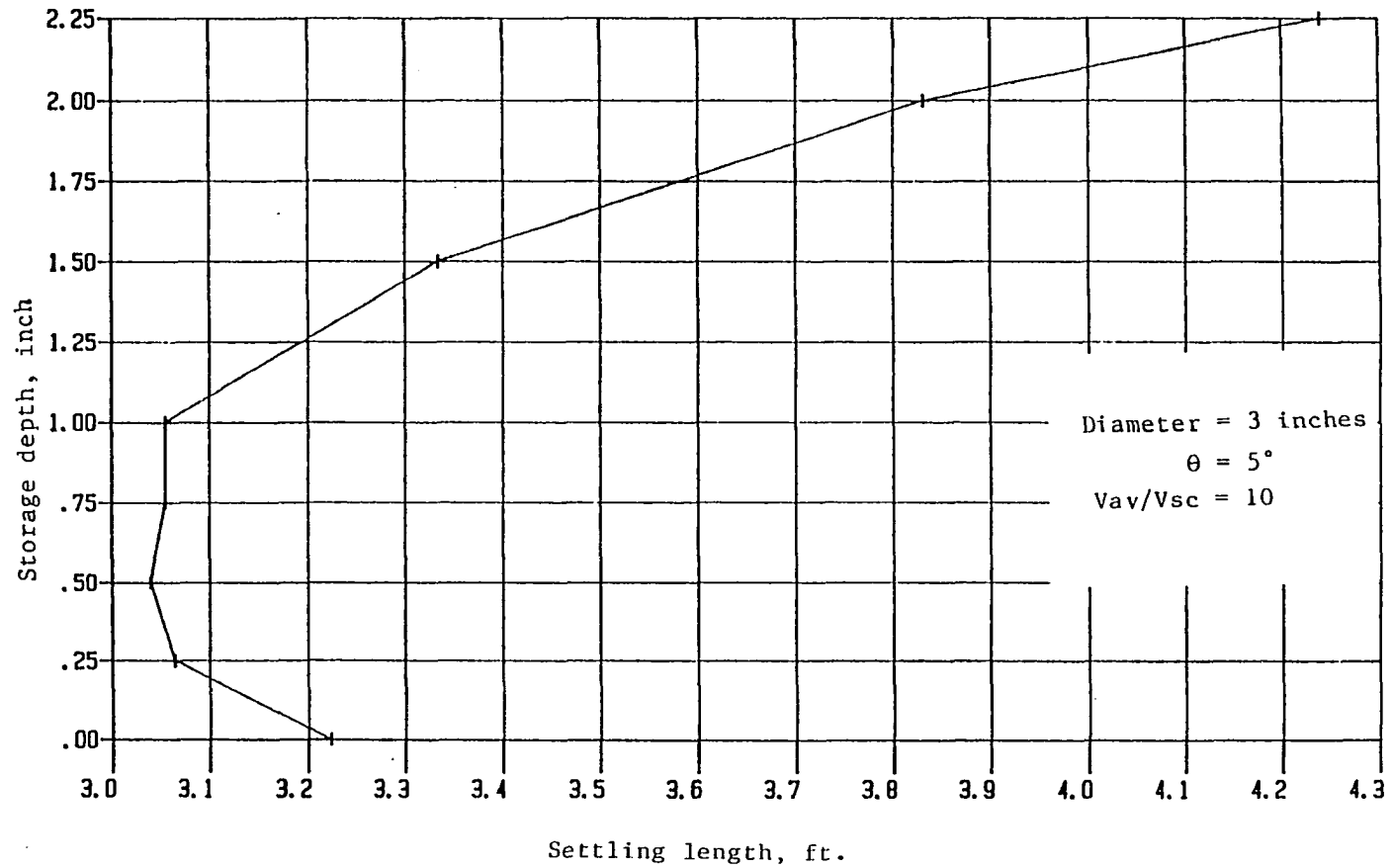

Figure 60. Sludge accumulation effects on the required length for an essentially horizontal tube settler with a 3-inch diameter

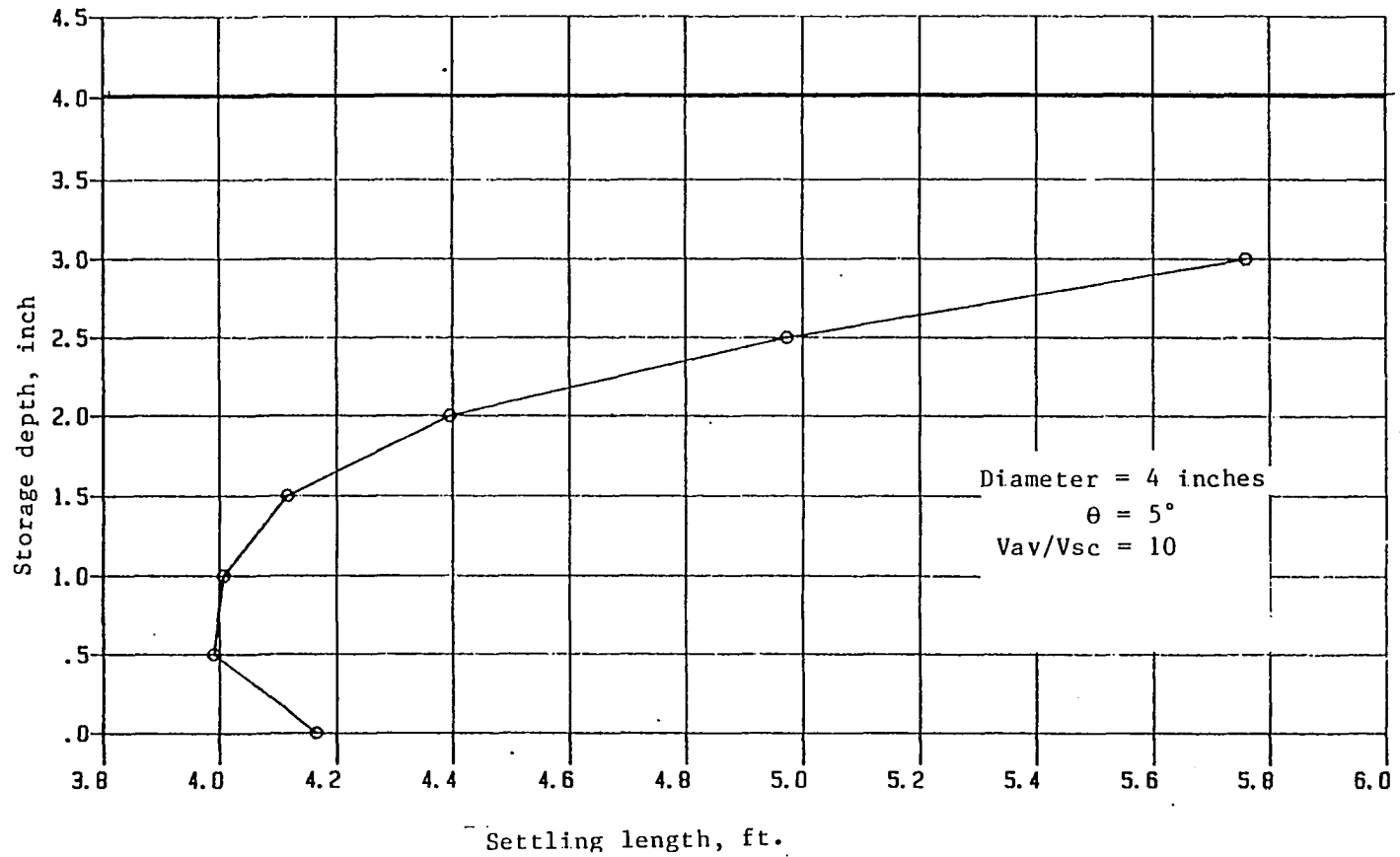

Figure 61. Sludge accumulation effects on the required length for essentially horizontal tube settler with a 4-inch diameter

EXPERIMENTAL STUDY

Previous research left two questions unsettled at the design and practical levels: "What is the actual particle trajectory in the tube?" and, "Will the design for the essentially horizontal tube be the same as that for the steeply inclined tubes?" Theoretical answers had been provided earlier by the author. The purpose of the experimental study was to investigate the validity of the theoretical answers. The experimental study was divided into two parts: first, a study was conducted to demonstrate the trajectory of the particles as predicted using the Fadel model; second, a study was conducted to evaluate the affect of sludge accumulation on the bottom of the tube on the essentially horizontal tubes performance. The experimental study was conducted in the sanitary engineering laboratories at Iowa State University.

Equipment and Materials

Equipment

As shown in Figure 62, the experimental equipment consisted of four main parts: the tube's water supply and inlet tank, the tube settler itself, the tube's outlet, and the equipment for feeding particulates at the top of the inlet to the tube.

The water supply used in the study was obtained from the building water supply and delivered to a constant head tank made from plexiglass and mounted on a steel platform. The tank overflow was wasted. The constant head tank was connected to a filter nozzle by a 3/4-inch garden

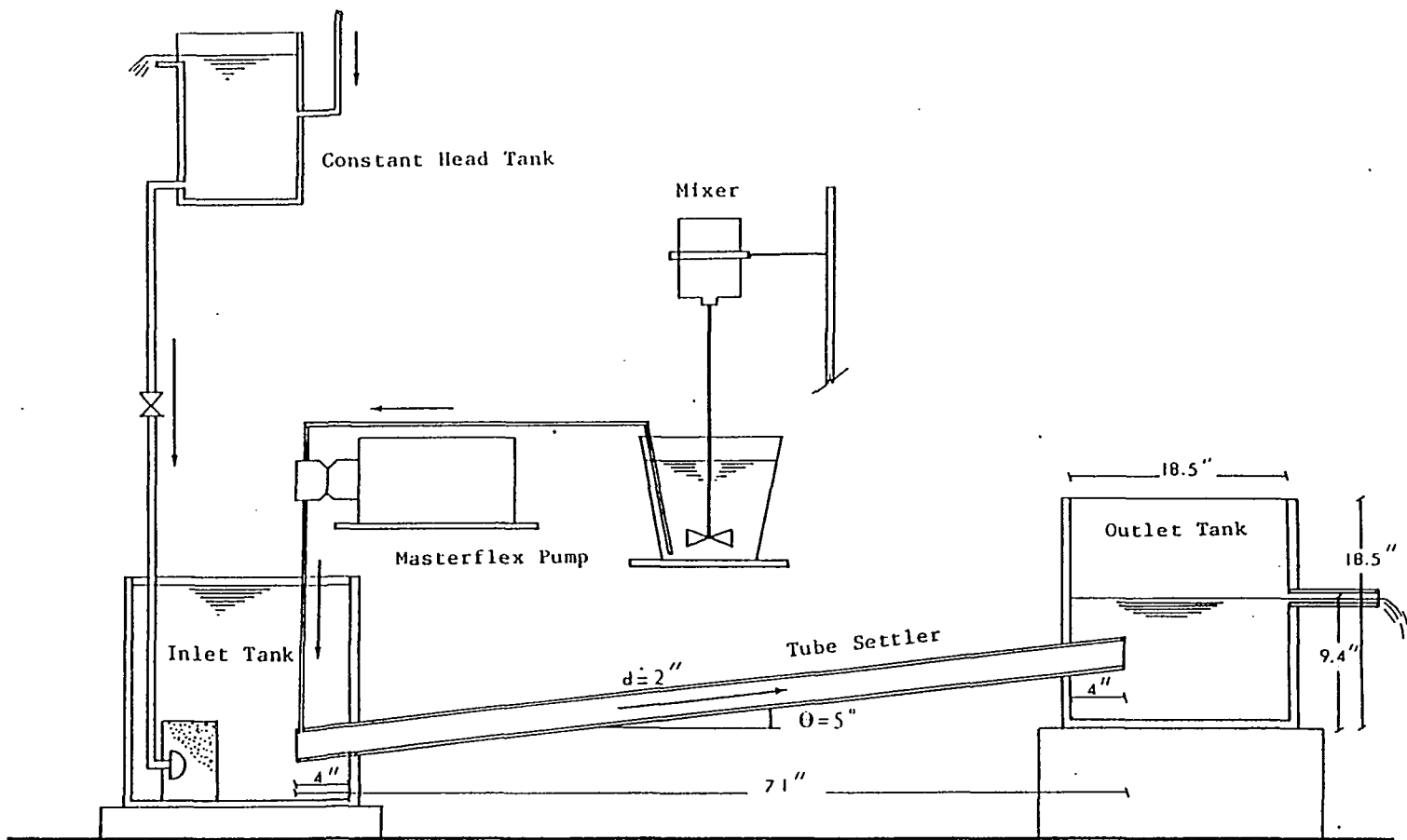

Figure 62. Schematic diagram for the experimental equipment

hose. The filter nozzle was made of plastic and had 0.04 inch openings; it was supplied by General Filter Company, Ames, Iowa. The nozzle was placed in a small box (5x5x5 inches) made of aluminum screen having openings of 0.4 x 0.4 inch. The box was filled with plastic beads (Cullsan P) provided by Culligan U.S.A., Northbrook, Illinois. The beads were cylindrical in shape and had a diameter of 0.06 inch and a length of 0.08-0.12 inch. The box was wrapped in cloth to keep the beads in place (box openings were larger than the bead dimensions) and to work as a filter for the tap water. The box was placed in a plexiglass tank with dimensions of 18.5 inches x 18.5 inches x 18.5 inches. The modification shown in Figure 63 was made after Run #15. The modification included: a) redesigning the inlet box to have dimension of 4x4x4 inches (box opening was 0.06 inch in diameter and made of stainless steel; the same beads were used). b) Hooking the inlet box on the wall of the plexiglass inlet tank facing the tube opening, as shown in the figure. c) Connecting the inlet hose from the constant head tank to the inlet box outside the plexiglass inlet tank.

The tube settler was mounted through a circular opening of 2.75 inches located 4 inches from the inlet tank bottom. The opening was provided with a 1/4-inch rubber "O" ring to seal off water around the tube settler.

Three plexiglass tubes were used at various times as tube settlers, Figure 64. Tube dimensions were: inner diameter of 2 inches, outer diameter of 2.5 inches, and length of 71 inches. Each tube was provided with a 1/2-inch circular opening at one end for the suspension inlet.

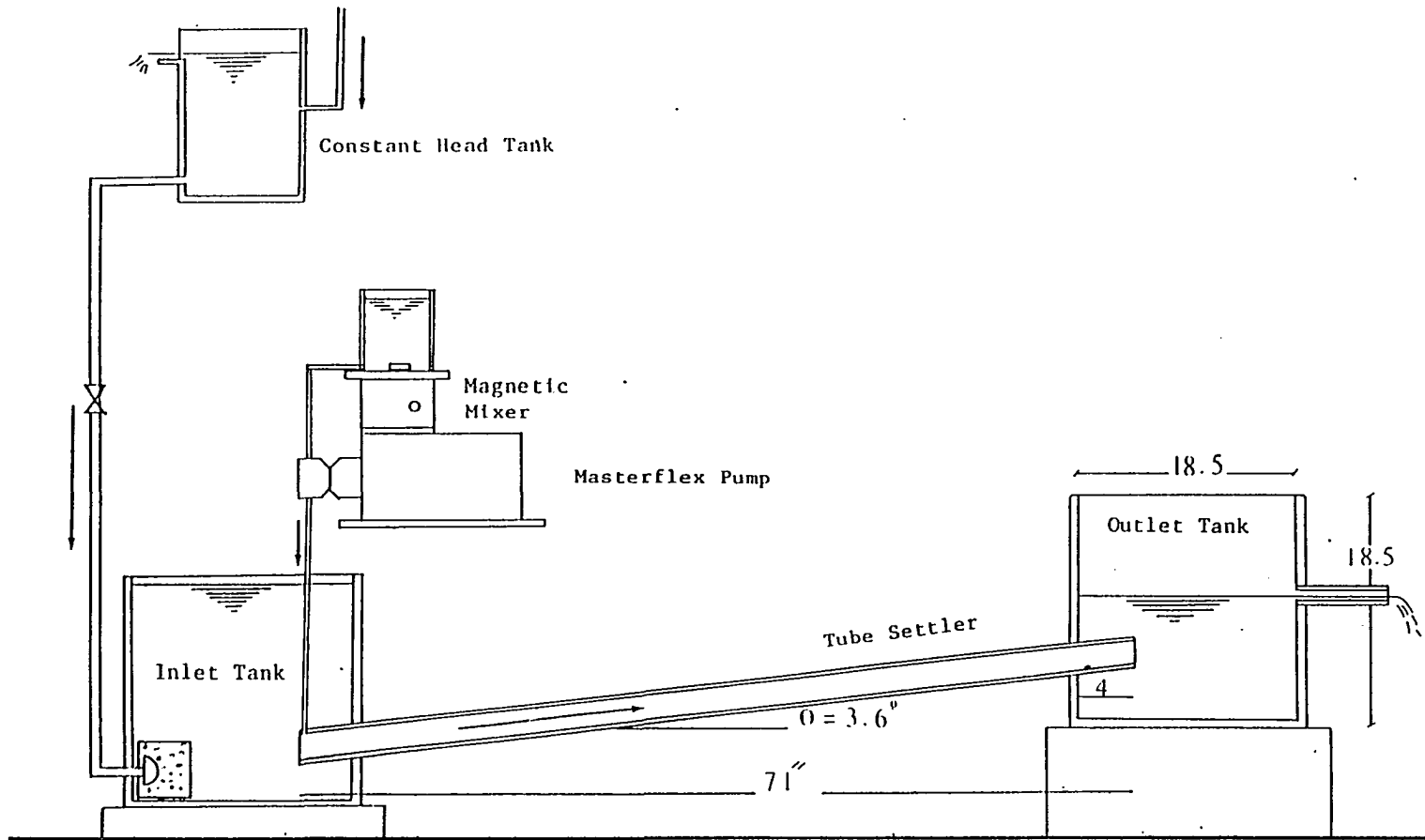
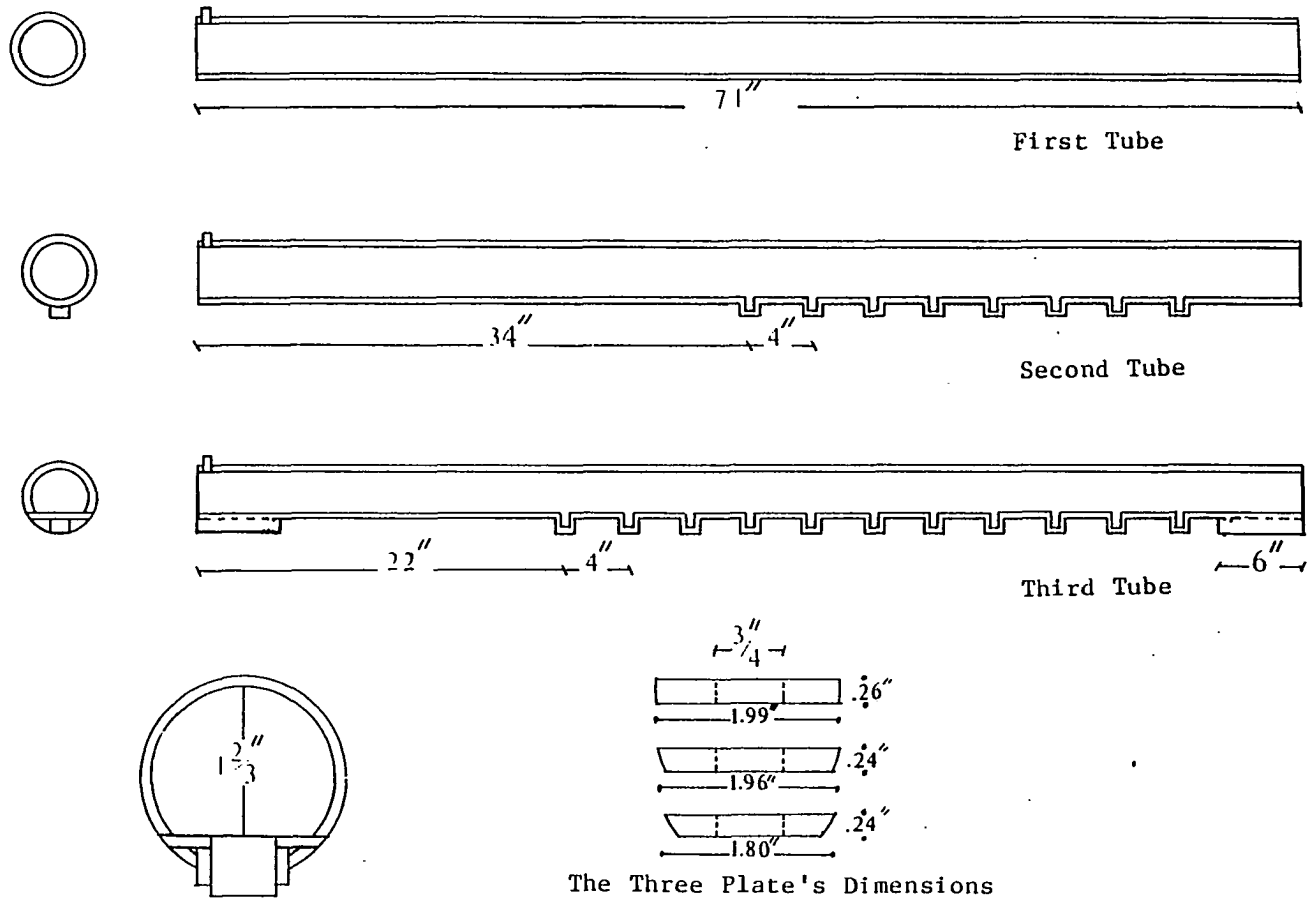

Figure 63. Schematic program for the modified experimental equipment



Enlarged cross-section of the third tube

Figure 64. Schematic diagram for the three tubes used in the experiment

One of the tubes was provided with eight copper cups ($3/4$ -inch) located at the tube bottom (considering the suspension inlet opening to be located at the tube top). The cups were spaced at 4-inch intervals with the first centered 34 inches from the tube inlet. The third tube was designed differently than the other two. A 0.32-inch section along its bottom was removed for the full tube length and replaced by a flat plate, except for 6 inches at each end of the tube. A flat plate was placed inside the tube to provide the same reduction of the total depth as that for the removed part. The third tube then can be considered as an open circular tube cross-section having a simulated particle depth equal to 0.32 inch. This design represents an essentially horizontal tube with 0.32 inch of its depth occupied by accumulated sludge. Eleven cups, described above, were provided along the flat bottom of this tube starting 24 inches from the tube inlet and spaced at 4-inch intervals.

Three plates were used to represent added depth of sludge accumulation on the bottom of the third tube. These plates have the same length as that of the tube; they were provided with $3/4$ -inch circular holes in the same locations as those in the third tube, permitting the settling experimental particles to be collected in the cups. The dimensions of the plates were as follows: The first plate has a width of 1.8 inches and a thickness of 0.24 inch; the second plate has a width of 1.96 inches and a thickness of 0.24 inch; and the third plate has a width of 1.99 inches and a thickness of 0.26 inch.

The tubes, when installed to the inlet and the outlet tanks, had 4 inches of their length at each end inside the tanks.

The outlet tank had the same dimensions as the inlet tank, with only one difference: the outlet tank was provided with an outlet overflow tube 1/2-inch diameter from which the water flowed to waste. The outlet tube was located on the opposite side the outlet tank, i.e., facing the 2.75 inch opening, and 9.5 inches from the tank bottom.

The suspension feeding system consisted of an 8-liter plastic bucket, a 1/30-horsepower mixer provided by Talpays Engineering Corporation, Emerson, New Jersey; an adjustable speed control for the mixer; and a Masterflex pump, Model No. 7565, provided by Cole-Parmer Instrument Co., Chicago, Illinois. The pump had several heads which could be mounted separately or in groups of 1, 2, 3, or 4 units. The head used in this study was Model No. 7014, which pumps water at adjusted rates up to 100 ml/min. The flow rate required can be adjusted by an adjustable control. The inlet to the pump was a 0.04 inch Tygon tube having its inlet side submerged in the suspension bucket. The pump's outlet was the same as its inlet except that a 2-inch long steel tube having the same diameter was attached to the outlet end. The steel tube was bent and placed in the top opening of the tube settler. The bent end was directed to the flow direction. A later modification placed the suspension bucket just above the Masterflex pump and used a magnetic stirrer instead of the mixer. Accordingly, a shorter inlet tube to the Masterflex pump was used. This tube was kept as nearly vertical as possible; the reasons for these modifications will be explained when the results are discussed.

Miscellaneous equipment

A microscope manufactured by the American Optical Scientific Instrument Division, Buffalo, New York, was used to magnify the settled glass beads in order to measure their diameters. A Polaroid camera was used to photograph the glass beads. A nest of sieves manufactured by the Allan Bradley Company, Milwaukee, Wisconsin, was used to sieve glass beads to obtain the range of desired diameters. The sieve openings used were 30, 45, 53, and 74 microns, with factory specification stating that the actual openings are within ± 2 microns of the stated openings.

Materials

Two materials were used to provide particulates as suspension in the study: diatomite and glass beads. The diatomite was provided by Johns Manville Product Corporation, Lompac, California. The diatomite grade used, Celite 535, has a median particle size of 25 microns and a size range of 5 to 175 microns. The glass beads were provided by the Fine Industrial Supply Corporation, Baldwin, New York. Eighty percent of the glass beads purchased were in the size range of 44 to 95 microns. They were spherical in shape and contained no more than 10% irregularly shaped particles. They were reasonably free of sharp angular particles, as well as particles showing milkiness, surface scoring, or foreign matter.

Suspension preparation

Two methods of preparing particles having a narrow size range were practiced. These are water elutriation and sieving analysis. The water

elutriation process was used for preparing the diatomite samples; the sieving process was used for preparing the glass bead samples.

The elutriation process was used in an attempt to prepare a suspension with a single settling velocity. The apparatus consisted of three glass tubes, each with a different diameter arranged vertically, as in Figure 65. The three tubes had a different lengths and diameters as shown in the figure. The lower tube had a diameter of 1.5 inches, the middle one had a diameter of 3 inches, and the top tube had a diameter of 6 inches. The inlet to the elutriation tubes was provided through a flow ratemeter and a needle valve, which controlled the flow rate through the tubes. Water flowed from the flow ratemeter into the bottom of the lower tube and up through the second and the third tubes, where it was discharged from the top of the third tube.

The elutriation process may be summarized as follows: If a sample of diatomite is placed in the lower tube, the particles with settling velocities equal to or greater than the water flow velocity in the bottom tube will remain in it, and the particles with settling velocity less than the flow velocity will escape to the second tube. Since the second tube has a larger tube diameter than the first, the fluid velocity becomes proportionally smaller. Thus, particles with settling velocities matching the flow velocity will stay in this tube, while the particles with lower settling velocities will escape to the third tube, and so on. Because diatomite particles have an irregular shape, the suspension collected in each tube will have a very wide size range.

The elutriation process time was continued until the particles

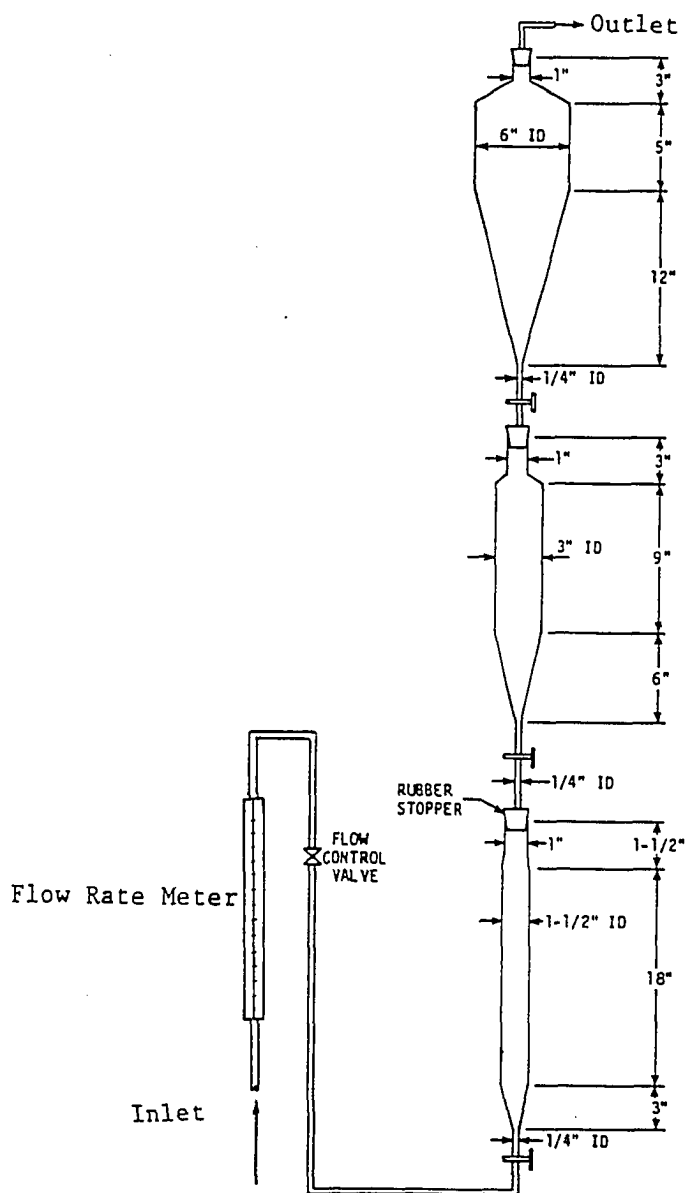

Figure 65. Schematic diagram presents the elutriation process equipment used in the experiment

become stationary and discrete, i.e., the time when the particles were no longer moving up or down. The time required to terminate the elutriation process varies with the flow velocity, longer times being required at low flow rates than high flow rates.

At the end of the elutriation process, the stopcocks were closed in the middle, then the top tube, and finally the lower tube. The middle tube was then separated from the system. A volume of water equal to the cone volume of the middle tube was then drained into a graduated cylinder to obtain the exact volume. The remaining water then was collected in a beaker. This water contained the particles used in the tube settler experiment.

The operation was repeated several times, until a considerable weight of particles was collected.

Disadvantages of the elutriation process

Several disadvantages to the elutriation process were discovered:

1. The three columns must be nearly vertical; since tube inclination disturbed the flow pattern and flow rotation occurred.
2. The stopcocks must be essentially vertical when opened; any minor tilting disturbed the flow pattern.
3. The cone in the column contains particles with a wide range of flow velocity, starting from the average flow velocity from the previous tube to the average flow velocity of the tube that includes the cone. However, this problem was reduced by wasting a water volume (and the particles contained therein).

4. The most critical disadvantage of this method was that the flow regime across the tubes is laminar; therefore, velocity profiles within the tube will change from uniform to parabolic. These velocity profiles will collect suspension having particles with wide range of settling velocities. This problem becomes more critical when the transition length (between uniform velocity profile and laminar flow velocity) is shorter than the tube length than that when the transition length is longer than the tube length. The velocity at which the transition length equals the tube length was found to be 0.13 ft/min.

Experimental Procedure

Two experimental procedures were used in this study. The first was designed to demonstrate the validity of the Fadel model as an accurate predictor of where particles would settle out. The second procedure was designed to examine the suggested behavior of the essentially horizontal tubes taking into consideration the effect of the settled solids accumulated on the tube bottom.

The following steps were assigned in the first procedure depending on the material of the suspension:

Using diatomite:

1. The diatomite particulate was prepared by the elutriation process.
2. After collecting a reasonable amount of the suspension, the suspension was placed in the plastic bucket and continuously

mixed.

3. The suspension was then fed to the inlet end of the tube settler at the top, using the Masterflex pump at a rate equal to the average flow velocity across the tube settler.
4. The uniform flow rate across the entrance to the tube settler was measured by recording the average time required to fill a 2-liter beaker. At least five replicates were timed and averaged.
5. When the average flow velocity across the tube settler and the flow velocity of the second elutriator tube are both known, the following quantities may be calculated:

a) Transition length in the elutriation tube. If this length is less than the 9-inch elutriation tube length, the average settling velocity for the particles will equal 1.33 times the flow velocity, and the maximum settling velocity will equal twice the flow velocity. The minimum settling velocity of the particles will be less than or equal to the flow velocity. If the transition length is larger than the column length, the "n" value will be less than 1.33. The "n" value then can be calculated and the average particle settling velocity will equal "n" times the flow velocity. The maximum settling velocity can be calculated using the Langhaar equation.

b) In each of the above cases, the particles settling velocity range can be determined and, the required settling length can be calculated using the Fadel computer program, and a settling range determined.

6. When the settling range is known, it can be compared with the actual location of the particles in the tubes at the end of the run. The validity of the model may then be determined by comparing the theoretical with the actual location of the particles.

Using glass beads:

The procedure described below was used in the remaining runs except Runs #5 and #6. These two runs were conducted using the same procedure used for the diatomite.

1. The suspension was prepared by mechanically sieving the glass beads. The glass bead size range used in the experimental work was 20 to 74 microns.
2. A small amount of monobasic sodium phosphate, which acted as a dispersant, was added to the glass beads suspension.
3. As with the diatomite, the suspension was fed into the tube using the Masterflex pump. The second tube having eight cups was used in these runs.
4. The flow rate was measured using a one-liter graduated cylinder and a stopwatch.
5. The run was terminated after a reasonable amount of glass beads lay on the bottom of the tube. Usually, a run lasted 16 to 24 hours at low flow velocities, and 6 to 9 hours in high flow velocities runs.
6. At the end of each run, the tube was tilted 20 to 40 degrees around the axis of the flow direction, and the two tanks were

drained by simultaneous syphoning with 1/2 inch tygone tubes (one for each tank). The tube is tilted in order to move the glass beads accumulated in the tube to a new position far from the cups. Thus, when the water backs up while the tanks are drained, the glass beads will not be carried to the cups.

7. After draining the two tanks, the cups were removed and a sample of the glass beads settled in four cups chosen at different locations was examined under the microscope.
8. The 1000x magnification lens was used to measure the diameter of unbroken spherical particles. Two or three pictures were taken at two to three locations in the same sample. Again, the locations of the photographs made were chosen to present the maximum possible number of unbroken spherical glass beads. If variation occurred in the measured diameters, the average diameters of those photographed was taken. The variation in the measured diameters was in the range of 1 to 3 microns, when particles having diameters of 22 to 46 microns were measured.
9. When both the diameter and the specific gravity of the glass beads are known, the particle settling velocities may be Stoke's settling velocities of the particles and the average flow velocity across the tube are known, the theoretical length at which the particle is predicted to settle may be found using the computer program.
10. The validity of Fadel's model then may be determined by

comparing the theoretical length with the actual length at which the glass bead particles were found.

The following operating steps were used in the second procedure in which the glass beads were the only suspension used:

1. For a specified flow, the previously noted steps one through nine were repeated to evaluate where the glass beads would settle in the tube with no sludge accumulation in the tube.
2. Using the same flow and the third tube, a complete run was then conducted in which the glass beads settled in tubes with a simulated sludge accumulation. Pictures were taken of the glass beads that settled in the same places as those in the first step.
3. Then, the first plate was placed on the flat bottom of the third tube. This added plate represents more sludge accumulation on the bottom of the tube. Again using the same flow, a complete run was conducted.
4. Step two was then repeated after adding the second and then the third plates. Again, a set of pictures was taken after each plate was added to represent additional sludge accumulation. The glass beads were collected in the same places as those collected in the previous runs.
5. A relationship between the ratio of storage depth to the tube diameter and the particles diameters at the same spots along the tube length was drawn.

5. Steps one through five were then repeated for different flow values.

RESULTS AND DISCUSSION

Twenty-five runs were conducted in the experimental study. Thirteen runs were conducted to demonstrate the validity of the Fadel model. Of these, four runs were conducted (Runs #1 to #4) using diatomite and nine runs (Runs #5 to #11 and Runs #16 and #21) were conducted using glass beads. In the second part of the study, twelve runs were conducted to determine the effect of sludge accumulation on the performance of essentially horizontal tubes.

The results of the diatomite runs and the first two glass bead runs were expressed in terms of the range of the distance of the settled diatomite or glass beads from the tube inlet. The later glass bead runs were used to determine the mean diameter of the settled glass beads, and their locations along the tube. The following discussion concerns results from the runs conducted to demonstrate the validity of the Fadel model.

Part 1

Run #1. (2/18/85)

This run was designated as the first run; it was conducted after 3 to 4 weeks of experience in running the system to determine final equipment and test procedure operating conditions. For example, the inlet box was first filled with gravel having a range of 1/2 to 3/4 inch diameter. When dye was used to study the flow regime, it was discovered that the flow distribution was not as uniform as it should be. It was then decided to change this media to the Cullsan P. In another early

trial, the suspension was fed by gravity through a very narrow tube placed in the 1/2-inch hole provided at the tube settler top. This method was troublesome. Every 1/2 hour, the feeding tube clogged with diatomite and cleaning was required. It then was decided to use the Masterflex pump, which eliminated the clogging problem.

In Run #1, the average flow velocity, V_{av} , was 3.54 fpm. The diatomite was elutriated with an average upward velocity of 0.319 fpm in the second tube, and 1.58 fpm in the first tube.

Using the computer program, the theoretical location for the settled particles indicated that, for the 1.48 fpm elutriation tube settling velocity and the 3.54 fpm tube settler V_{av} , the settling length should be 0.43 ft, and for the 0.319 fpm elutriation tube velocity, the settling length should be 2.214 ft. The observed range was 0.43 to 3.0 ft, with most of the suspension in the range of 0.9 ft to 2 ft. These results were quite encouraging, but confusing. However, the fact that we are dealing with a circular tube (the second tube) in the elutriation process reduces this confusion. The second tube will have a velocity profile and a transition length similar to that found in the tube settler. Accordingly, there will be a range of settling velocities rather than a single value of settling velocity particles. Knowing that the maximum average velocity for a transition length of 9 inches is 0.13 fpm, one realizes that lower velocities yield wider settling length ranges and higher velocities yield narrower ranges.

A complete laminar flow velocity profile will be established inside the elutriation tube at velocities less than 0.13 fpm. The maximum

upflow elutriation tube velocity will equal twice the average velocity; i.e., the particles will have settling velocities ranging from the average velocity to twice that value. On the other hand, for higher velocities, the maximum velocity will be less than twice the average velocity. Accordingly, the particles elutriated will have settling velocities ranging from average velocity in the elutriation tube to less than twice that value.

In this run, the average settling velocity used in the elutriation process was higher than 0.13 fpm. Accordingly, the maximum velocity will be less than twice the 0.319 fpm used. However, some of the particles used in this run had settling velocities less than the average flow velocity in the second tube. Accordingly, the range over which the particles settled in the tube settler can be considered applicable and promising but not confirming.

Run #2. (2/20/85)

A lower average tube settler flow velocity of 2.94 fpm was used in this run, and particles with a lower settling velocity were prepared using the elutriation process. The average velocity in the second tube was 0.244 fpm. The cone in the second tube was drained at the end of each elutriation process to remove particles having velocities higher than those found in the second tube and lower than those in the first tube (volume was 235 ml).

The particles settled were located at a distance of 1.4 to 2.77 ft from the tube settler inlet. According to the computer solution, particles with a settling velocity of 0.244 fpm settled in a

2-inch tube settler with an average settler tube velocity of 2.94 should settle at a distance of 2.5 ft from the tube settler inlet. Again, as in the first run, we are dealing with a range of settling velocities and not a single value, so the observed range of tube length where settling occurred is not surprising. Using the Langhaar Equation (19), the maximum velocity inside the second column can be calculated. The maximum velocity was found to equal 1.95 times the average velocity, i.e., 0.476 fpm. This settling velocity will give a settling length of 1.22 ft. Again, the range is considered reasonable but the Fadel model is unconfirmed.

Run #3. (2/22/85)

In this run, the flow average velocity through the tube settler was 2 fpm and the average upward velocity used in the elutriation process was 0.14 fpm. The maximum settling velocity was twice 0.14 fpm; i.e., 0.28 fpm. The settling range where the particles were found was 1.5 to 3.5 ft from the tube inlet. The computer solution showed that the expected range should be 3.139 ft for the 0.14 fpm (V_{sc}) particles to 1.487 ft for the 1.28 fpm (V_{sc}) particles.

Run #4. (2/25/85)

A lower particle settling velocity was used in this run, but the tube settler velocity was kept the same. The average particle settling velocity was 0.1 fpm ($<.13$ fpm) and the maximum was 0.2 fpm.

The experimental results showed that the particles settled over a range of 2.00 to 4.2 ft from the inlet; the computer-projected range was

2.16 to 4.44 ft. Again, there is a good agreement between the observed and the computed location of the settled particles.

Run #5. (2/27/85)

In this run, glass beads in the size range of 45 to 53 microns were used instead of diatomite. The tube settler flow velocity used, V_{av} , was 4.20 fpm. Using Stoke's Law, the glass beads with a diameter of 45 microns will have a settling velocity of

$$V_{sc} = \frac{980 \text{ cm/sec}^2 (2.5 - 1) (0.0045 \text{ cm})^2}{18 \times 0.012 \text{ cm}^2/\text{sec}}$$

$$= 0.138 \text{ cm/sec}$$

$$= 0.272 \text{ fpm (45 micron glass bead).}$$

For the 53-micron beads, V_{sc} is equal to 0.377 fpm. The range over which the particles settled in the tube settler found in the tube bottom was 2.0 to 3.4 ft, while the computer range was of 2.28 to 3.23 ft. It was noticed that the observed range was a little wider than computed because the actual sieve openings were ± 2 micron. Accordingly, the actual range to consider is 43 to 55 microns. This glass head size range gave a settling velocity range of 0.248 to 0.406 fpm with a computer-predicted settling range of 2.1 to 3.56 ft.

The experimental results are in good agreement with the predicted results. However, a thin line of settled glass beads lay on the tube bottom from the observed range to both ends of the tube. The explanation for the presence of this line is that particles smaller than the range specified were sieved with the sample. They could be stuck with

other sieved particles. These particles had lower V_{sc} than the settling velocity of the 43-micron particles. Also, irregular particle shapes such as half spheres, rods, etc., could be sieved within the range of 43 to 55 microns. These particles would have settling velocities higher or lower than the spheres. For example, cylinder-like particles have a lower drag coefficient than spherical particles, Figure 1. Accordingly, the cylindrical particles will have a higher settling velocity than the spherical particles, and will settle earlier in the tube.

Run #6. (3/5/85-3/6/85)

The tube settler flow velocity was set to equal 5.08 fpm. This flow velocity gave a Reynolds number of 1055 based on the tube diameter. The range of glass bead sizes was from 51 to 76 microns (actual range). The glass bead settling velocities were then from 0.35 to 0.76 fpm. At the end of the run, most of the particles were laying from of 1.1 to 2.80 ft from the tube inlet. The computer results indicate that the beads were predicted to lay from is 1.25 to 2.98 ft from the tube inlet.

General Comments, Runs #1 - #6

The results obtained from Runs #1 to #6 indicate that a reasonable agreement exists between the observed and the calculated location of the particles in the tube settler. Although these runs were nearly successful, neither elutriation nor the sieving processes were as helpful as expected. The results are not a confirmation of the Fadel model. A confirming result would be one demonstrating that the settled

particle can be picked up and its actual settling velocity calculated. Using this particle settling velocity, the computer-projected solution should provide a calculated settling length equal to the actual settling length observed. A modified procedure based on this premise may be accomplished by using the second tube, where the eight cups work as traps for the settled particles. Accordingly, at this stage of the study, it was decided to conduct a few runs using the second tube in order to measure the diameters of particles collected in the eight cups.

Run #7. (3/17/85)

The second eight-cup tube was used in this run. The average tube settler flow velocity was 3.5 fpm. Glass beads in the size range 35 to 47 microns were fed through a tube having an inner diameter of 1/16-inch and outer diameter of 1/8-inch. The suspension feeder was connected to the top of the tube settler wall.

After 12 hours the run was terminated and microphotographs were taken of the glass beads trapped in the first, fourth, and seventh cups. Table 7 shows the cup number, the distance between the inlet and the specified cup (equal to the settling length), the glass bead particle diameter found in the specified cup, the settling velocity, V_{sc} , for the particles, and the computed predicted distance along the tube settler where the particle should settle.

The computer-predicted length = (the length computed according to the run conditions of V_{av} , V_{sc} , and diameter) - (the effect of letting the particles enter the tube 1/8 of an inch lower than the tube top (i.e., the computer output gives the settling length for particles

Table 7. Results and computer-predicted results in Run #7

Cup#	Distance ^a ft	Particle Diameter microns	Vsc fpm	Computer-predicted location, ft
1	2.85	44.00	0.250	2.83
4	3.85	38.75	0.192	3.84
7	4.85	33.80	0.152	4.94

^aDistance from the inlet.

entering the tube from the uppermost point until settlement). The correction can be found by using the first option in the computer program (Appendix A), which allows us to trace the particle trajectory across the tube. This option was used in presenting Examples 1 through 6 (under the theoretical study). Knowing the outer diameter of the suspension feeder tube, which equals 0.011 ft, the distance the particle will travel from the tube inlet until it reaches this depth can be found using the above option. The distance was found to equal 0.07 ft.

Comparisons between settling lengths predicted by the different models discussed in the literature review and the Fadel model are presented in Table 8.

Another observation should be mentioned here. Even though the sieving range was from 35 to 47 microns, particles with diameters of less than 35 microns were found in cup #7.

Table 8. A comparison between the different models using Run #7 data

Cup #	Yao		Willis	Culp	Fadel	actual length, ft
	model	recommended design length				
1	3.11	6.22	2.34	2.33	2.83	2.85
4	4.04	8.09	3.04	3.03	3.84	3.85
7	5.12	10.73	3.85	3.84	4.94	4.85

Run #8. (3/19/85)

After the very successful Run #7, it was decided to reduce the average flow velocity in the tube settler to 1.85 fpm in Run #8. During Run #8, the author observed that a large number of the particles that entered the tube settler were large-sized and settled rapidly. Before they reached the middle of the tube, however, the agglomerated particles began to disperse into a large number of much smaller particles. These smaller particles settled much more slowly when dispersed than when they were flocculated together. In short, small particles which flocculate prior to entering the tube settler form larger particles which settle faster until they hit a region of high local velocity close to the tube center where they start to separate into the original small particles. Such a situation leads to faulty results. Another problem was also observed associated with the suspension feeding tube. The flow velocity (at the minimum flow of the Masterflex pump) exiting this tube was two times the average flow velocity of the tube settler. Both of

these conditions will lead to shorter observed settling lengths than those predicted based on the settling of discrete particles. Before the termination of the run, a sample of the glass bead laid at the end of the tube was pulled out by a means of a pipette. The diameter of these glass beads was found to equal 20 microns. This diameter of particle has a settling velocity of 0.051 fpm. For this settling velocity and at the average flow velocity in the tube settler, the required settling length projected by computer is 8.08 ft. However, these particles were located only 5.9 ft from the tube inlet. The effect of these two conditions led to an error of 2.16 ft.

Run #9. (4/20/85)

The results of Run #8 caused the author to increase the mean tube settler velocity to overcome these effects. The tube flow velocity was increased to 2.9 fpm. Better results were obtained than in Run #8, but they were not as good as those obtained in Run #7. Table 9 presents the results and the computer-predicted location of the particles collected in each cup.

The tube carrying the particles from the suspension bucket to the Masterflex pump was almost 3/4 full of particles; these rolled in very slow motion. Also, at the outlet feeding tube, the particles exited in large numbers at one time, resembling hindered rather than discrete settling. Again, the first effect mentioned in Run #8 still existed, but the particles separated faster than those in Run #8.

Table 9. Results and computer-predicted results in Run #9

Cup #	Distance, ^a ft	Particle diameter, microns	Vsc, fpm	Computer-Predicted, location, ^a ft
1	2.85	38.00	0.194	3.03
5	4.19	32.00	0.138	4.38
7	4.85	29.00	0.113	5.35

^aDistance from inlet.

Run #10. (4/5/85)

In this run, suspension feeding tube was replaced by a larger diameter tube in order to match the flow of suspension exit from the feeder with that of the tube settler. The inner diameter of the new feeder tube was 1/8 inch, the outer was 3/16 inch. A dispersant was added to the suspension (monobasic sodium phosphate) to keep the particles dispersed. The mean flow rate in the tube settler in this run was 2.25 fpm. Table 10 presents the results.

While the results were not as expected, they were better than those obtained in Run #9. The researcher noticed, after the run started, that the delivery pipe was carrying too many particles--even with presence of the dispersant material--and the particles exiting the tube were clustered together. This may be explained since (1) the particles clustered together. This may be explained since (1) the particles came very close to each other in the feeding system such that the dispersion effect was not apparent, or (2) the amount of dispersant was

Table 10. Results and computer-predicted results in Run #10

Cup #	Distance, ^a ft	Particles diameter, microns	V _{sc} , fpm	Computer-predicted Location ^a , ft
1	2.85	32.00	0.138	3.38
3	3.52	29.00	0.113	4.18
6	4.52	25.10	0.085	5.70

^aDistance from the inlet.

insufficient. Also, an air bubble was found in front of the feeding tube outlet which drove the particles downward when they left the feeder. This air bubble was formed by the action of the mixer inside the suspension tank when the tank became half full.

Run #11. (4/6/85)

Another modification, consisting of cutting the suction tube length to a minimum by placing the suspension tank on the top of the pump was made. Accordingly, a magnetic stirrer replaced the mixer and a two-liter plexiglass tank having the suspension outlet at its bottom replaced the plastic bracket. The suspension inlet inside the tank was kept vertical to prevent air bubbles from entering the suction tube. The suction tube itself was also kept vertical as shown in Figure 64, to reduce the particle's retention time in the suction tube. Whenever the particle enters the suction tube, it will fall by gravity as well as by the suction action from the pump to the pump head.

In Run #11, the average tube settler flow velocity was 3.00 fpm.

The results showed a significant improvement. Table 11 shows these results.

Table 11. Results and computer-predicted results in Run #11

Cup #	Distance ^a ft	Particles diameter, microns	Vsc, fpm	Computed-Predicted Location, ft
1	2.85	37.60	0.190	3.15
3	3.52	34.50	0.160	3.82
5	4.19	32.70	0.144	4.45
7	4.85	30.00	0.121	5.22

^aDistance from inlet.

The observed error in this experiment may be due to the high suspension concentration used. Since the number of particles leaving the feeding tube was still high, it was decided to use a lower concentration suspension (3 grams of glass beads in the two-liter tank).

Runs #12 to #15 were used to study the effects of sludge accumulation on the performance of the essentially horizontal tubes where a flow of 0.065 cubic ft/min, giving a 3 fpm Vav for full diameter tube, was monitored as a continuation for Run #11.

Run #16. (4/11/85 to 4/13/85)

In this run, a very low suspension concentration and a tube settler flow velocity of 2fpm were used. The run lasted 48 hours, until a considerable amount of glass beads lay in the tube bottom. The results were very encouraging, as shown in Table 12. Figure 66 shows a

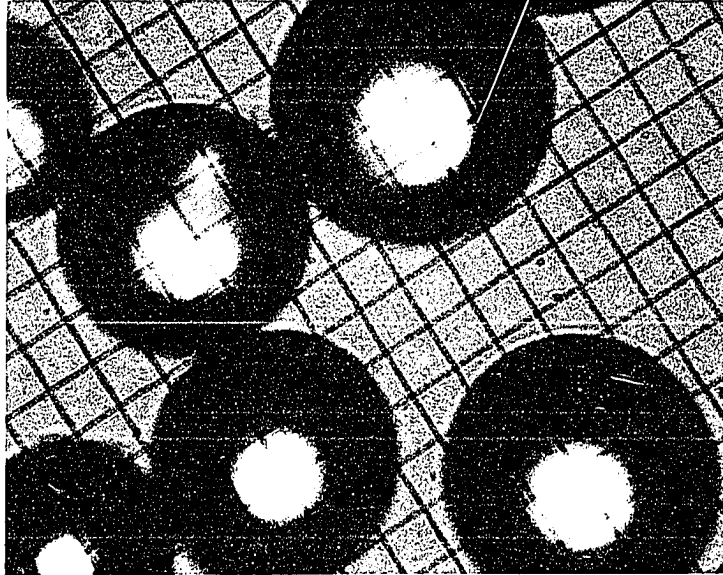

Figure 66. Glass beads (bulk) used in the study

microphotograph of the bulk glass beads used in the study. Figures 67 to 70 are microphotographs of the glass beads settled in cups 1, 3, 5, and 7 in this run.

Table 12. Results and computed-predicted results in Run #16

Cup #	Distance ft	Particles diameter, microns,	V _{sc} , fpm	Computed-Predicted Location, ^a ft
1	2.85	32.20	0.140	3.06
3	3.52	30.00	0.121	3.55
5	4.19	28.20	0.104	4.18
7	4.85	26.00	0.090	4.87

^aDistance from the inlet.

Run #21. (4/25/85)

In this run, the tube settler flow velocity was increased to 4.0 fpm. The suspension concentration was higher than that used in Run #15 because of the higher tube velocity. The run was successful and the observed lengths almost matched the computer-predicted location of the particles, as shown in Table 13.

The difference of 4.4 inches between the actual and computer-predicted location of the 34.50 micron beads found in the seventh cup could result from: (a) assuming a straight-line trajectory between two consecutive velocity profiles (the error generated from this assumption will be higher when higher tube settler velocities are encountered); (b)

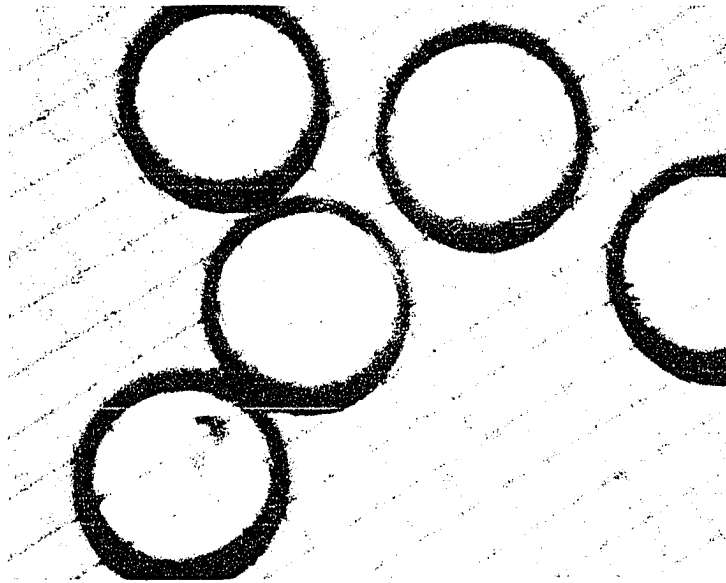

Figure 67. Glass beads settled at the tube end, cup #1, Run #16

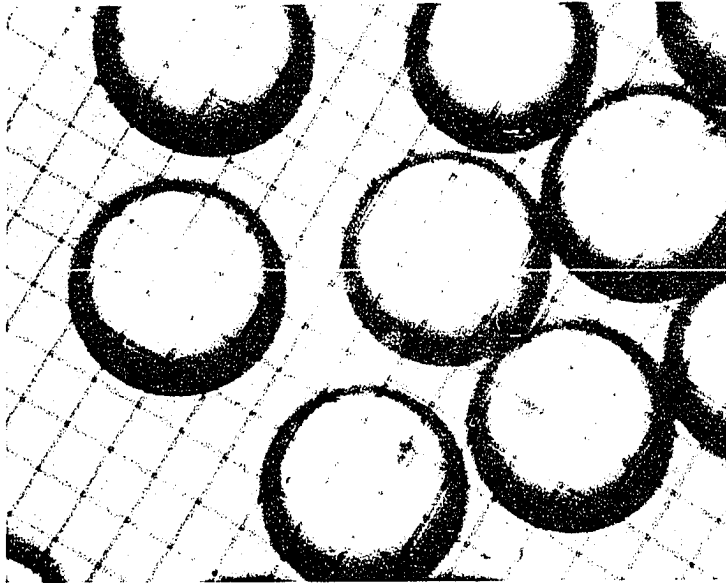

Figure 68. Glass beads settled at the tube end, cup #3, Run #16

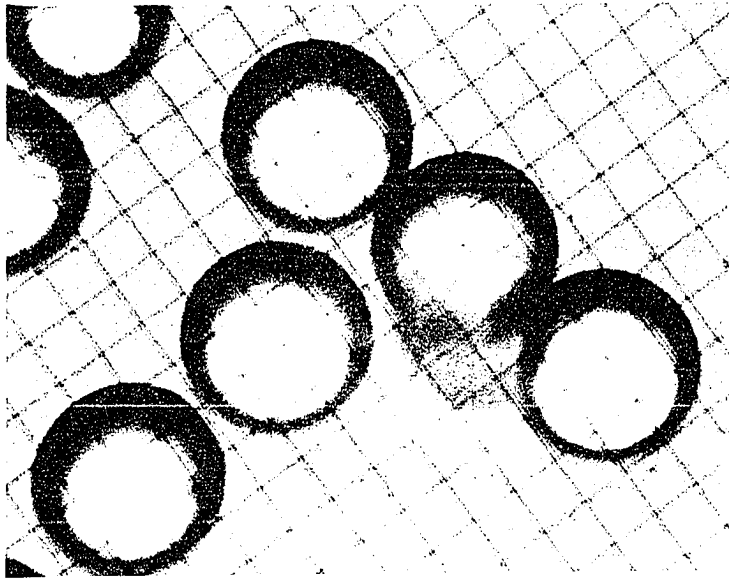

Figure 69. Glass beads settled at the tube end, cup #5, Run #16

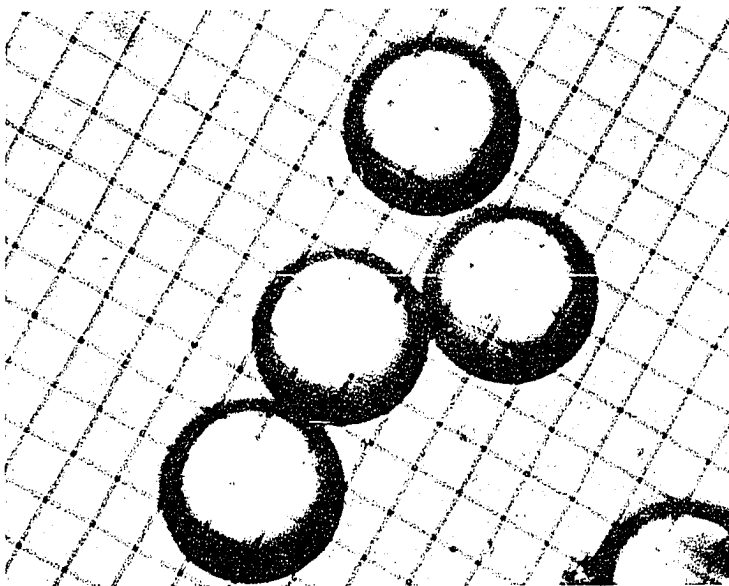

Figure 70. Glass beads settled at the tube end, cup #7, Run #16

Table 13. Results and computer-predicted results in Run #21

Cup #	Distance, ft	Particles diameter, microns	Vsc, fpm	Computed-predicted Location, ft
1	2.85	45.65	0.280	2.85
3	3.52	41.00	0.226	3.54
5	4.19	37.50	0.189	4.37
7	4.85	34.50	0.160	5.22

the allowable 1% error of the computer program gives a 0.6 inch error at cup #7; and, (c) the interval depths in calculating the required settling length in the computer program were chosen to equal 0.05 of the tube diameter. A smaller value could lead to more accurate results but would be a more time consuming program to run.

The accumulation of these effects on the generated calculation of settling length using the computer program increases with distance as the particle travels through the tube. This can be detected by comparing differences found in cup #5 with that of cup #7. In cup #5 the error was 2.16 inches while in cup #7 the error was 4.4 inches. These differences were also observed in Runs #7 and #11.

General Comments on Runs #7, #11, #16, and #21

The trend of the results showed that certain precautions should be taken to obtain a successful run:

1. The suspension concentration should be as low as possible.

2. The velocity of the suspension exiting the feeder should match the tube average flow velocity.

3. The suspension feeding should be initiated only after establishing a uniform flow pattern in the tube settler. This can be detected by feeding a dye solution through the suspension feeder.

4. The suction pipe from the suspension tank to the pump's head should be as short as possible to prevent the accumulation of glass beads in the suction pipe.

The results of Runs #7, #9, #11, #16, and #21 illustrate the applicability of Fadel's model.

Part 2

In this phase of the study using the same sample of glass beads as in previous ones, the variables used were as follows:

<u>Set #</u>	<u>Run #</u>	Tube Settler Average	Sludge
		<u>Flow Velocity, fpm</u>	<u>Accumulation, in</u>
1	11	3.00	0.00
	12	3.35	0.32
	13	3.89	0.56
	14	7.79	0.80
	15	6.49	1.06
2	16	2.00	0.00
	17	2.23	0.32
	18	2.59	0.56
	19	3.19	0.80
	20	4.33	1.06
3	21	4.00	0.00
	22	4.46	0.32
	23	5.19	0.56
	24	6.38	0.80
	25	8.66	1.06

Set #1

The first run in this set was Run #11. The remaining four runs in this set were conducted under the same conditions of suspension concentration and feeding tube outlet diameter. As mentioned earlier, the third tube was used. A complete run, as described in Run #11, was conducted and the the glass beads settled in cups 1, 3, 5, and 7 were collected and photographed. Subsequent runs in the set were made after adding the first, the second, and the third plate to simulate the accumulation of sludge. The results of these runs are listed in Table 14.

Figure 71 presents the relationship between the depth reduction ratio, ds/D , and particle diameter for the four locations along the tube settler. The ds/D ratio represents the relative depth occupied by the

Table 14. Diameter of glass beads collected in the cups in Run set #1

Cup #	Distance, ft	Glass bead diameter, microns				
		full tube	0.32" sludge	0.56" sludge	0.80" sludge	1.06" ^a sludge
1	2.85	37.60	36.50	32.00	34.20	46.40
3	3.52	34.50	33.47	29.00	31.20	33.50
5	4.19	32.20	30.43	26.35	28.15	30.00
7	4.85	30.00	28.15	24.35	25.80	27.40

^a Flat plate thickness to simulate sludge accumulation.

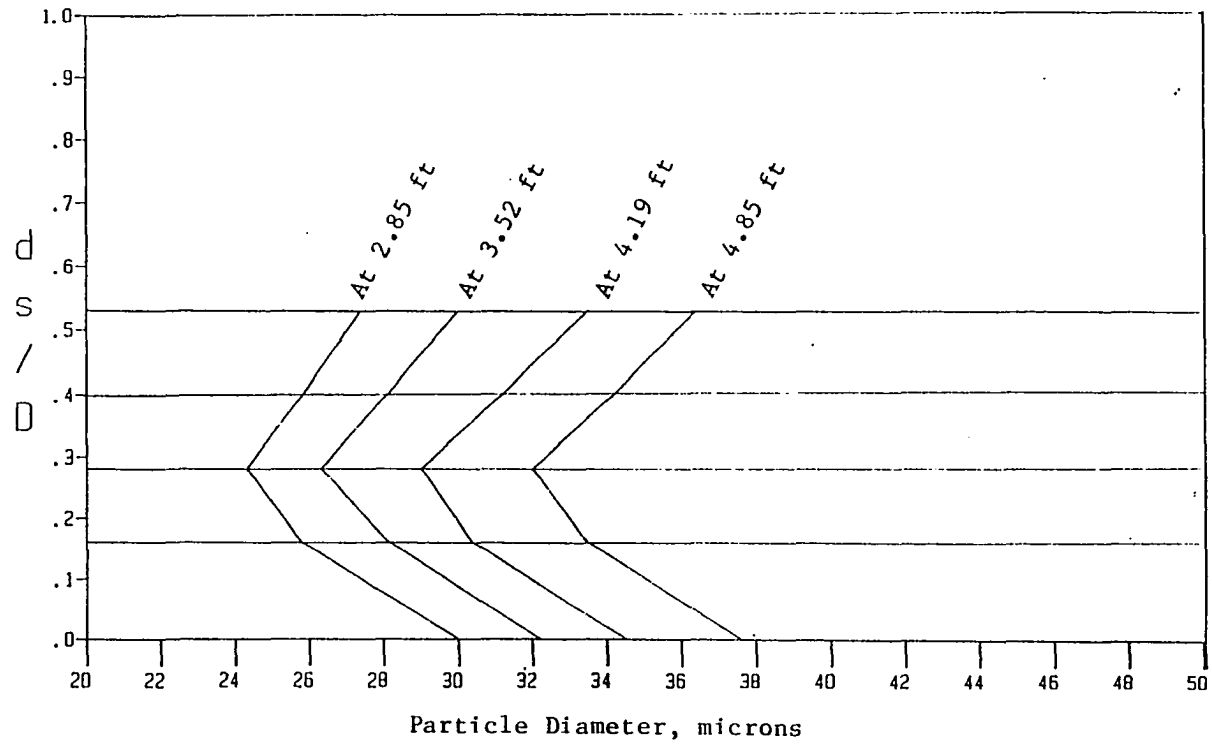

Figure 71. The relationship between the depth reduction ratio (ds/D) and particle diameter in Set #1

settled sludge in the bottom of the tube settler.

Set #2

The procedure used in the above set was also followed with an average tube velocity of 2 fpm, assuming a full-tube diameter. The results are illustrated in Table 15 and shown in Figure 72.

Set #3

The runs conducted in this set followed the operating procedures of Set #1 and Set #2. The full-diameter average flow velocity in the tube settler was 4 fpm. Table 16 and Figure 73 shows the results obtained.

Table 15. Diameter of glass beads collected in the cups in Run set #2

Cup #	Distance, ft	Glass bead diameter, microns				
		full tube	0.32" sludge	0.56" sludge	0.80" sludge	1.06" sludge
1	2.85	32.20	29.67	20.60	31.00	32.00
3	3.52	30.00	28.91	28.10	28.80	29.60
5	4.19	28.20	26.63	25.67	26.60	26.45
7	4.52	26.00	24.35	23.36	24.00	25.00

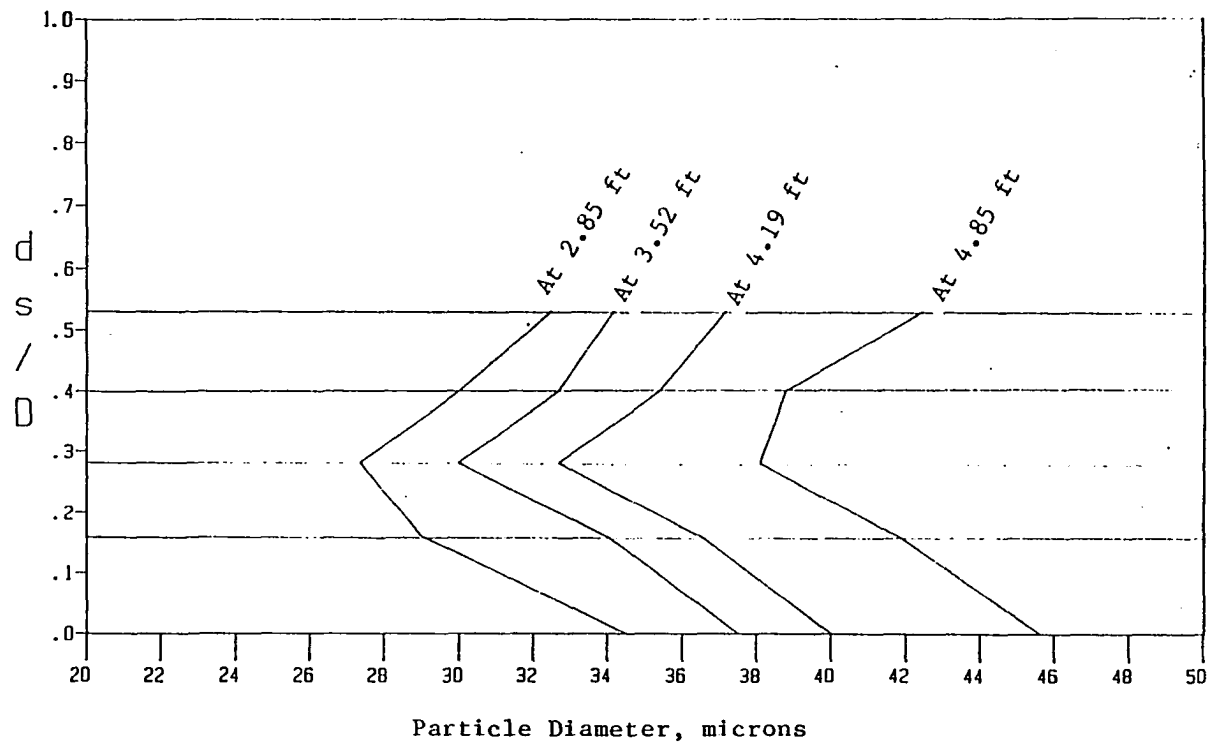

Figure 72. The relationship between the depth reduction ratio (ds/D) and particle diameter in Set #2

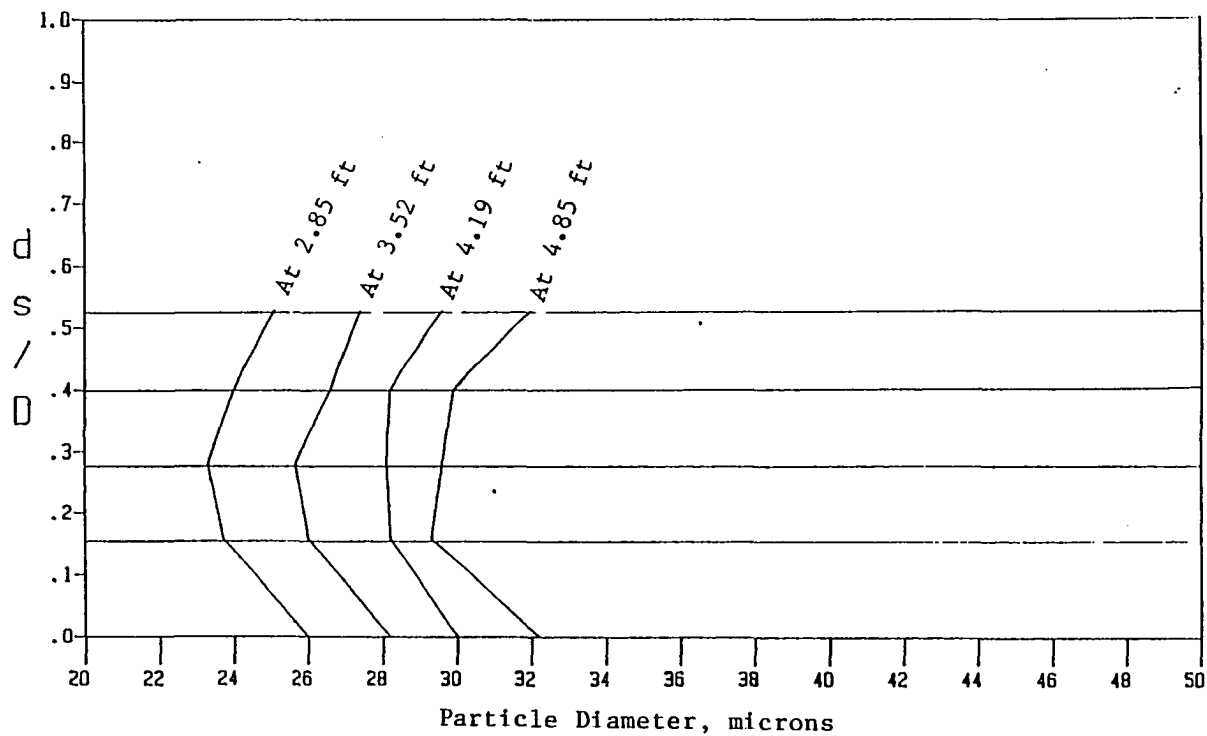

Figure 73. The relationship between the depth reduction ratio (ds/D) and particle diameter in Set #3

Table 16. Diameter of glass beads collected in the cups in Run set #3

Cup #	Distance, ft	Glass bead diameter, microns				
		full tube	0.32" sludge	0.56" sludge	0.80" sludge	1.06" sludge
1	2.85	45.65	42.00	38.80	38.84	42.60
3	3.52	41.00	36.50	32.00	33.38	37.20
5	4.19	37.50	34.00	29.67	32.72	34.20
7	4.85	34.50	29.00	27.38	30.00	32.50

General Discussion on the Run Sets Conducted in Part 2

The three sets of runs showed the same pattern: The diameter of the particles collected in the same cup decreased until the reduction of the tube diameter reached 0.56 inch, then the particle diameter increased with increasing sludge depth. In Figures 71 through 73, the pattern was consistent in the three sets.

One can easily see the difference between the theoretical effect of sludge accumulation in tubes (Figures 60 and 61) and the the actual experimental results (Figures 71 and 73). Figures 60 and 61 suggest that whenever ds/D reaches 0.4, the settling length (or the settled particle diameter) will begin to exceed that for the empty tube. Figures 71 through 73, based on experimental results, suggest that even

when ds/D equals 0.53, the required settling length in a tube with substantial sludge accumulation is still less than that calculated for an empty tube using the Fadel model. The difference between the two patterns result from the assumptions made in the theoretical study, which did not consider the effect of having flat bottomed velocity profiles inside the tube. Also, the assumptions neglected the effect of the wide horizontal velocity profile on the narrow vertical profile we are dealing with. However, the experimental pattern resulting in diameter decrease and then increase matches the pattern suggested by theory.

Actually, there is little or no information available in the literature which helps to evaluate or calculate velocity profiles under operation conditions in which sludge has accumulated in the tubes.

The question which must now be answered is not how to develop a model to handle the sludge accumulation (which is beyond the scope of this study), but to suggest how the designer can gain from these results. The shape of the sludge accumulation inside the tube will depend on particles concentration, particles size distribution, and particles inlet distribution to the tube. A survey study of existing treatment units is required to determine these shapes. The actual configuration may be considered to behave like the theoretical configuration assumed in the model development. However, as a factor of safety, a 40% reduction in the depth could be considered as the maximum allowable sludge accumulation, meaning that the designer should set the backflush timing to begin when sludge accumulation reaches 0.4 of the

tube depth.

The above discussion illustrates that the designer can use the Fadel model for designing both the essentially horizontal and steeply inclined tube configurations, except that one must monitor the backflushing process in the essentially horizontal tubes. Simple calculations will be required to determine the time interval between backflushing. For example, for a treatment plant which treats water carrying 100 ppm of suspended solid in a tube settler having an 80% removal efficiency, 80 ppm of solids will be collected in the tubes. The average flow velocity inside the tubes is assumed to be 2 fpm and the diameter to be 3 inches and its length to be 6 ft. The storage volume allowed per foot of length at 0.4 ds/D will equal 0.0151 ft^3 . This volume will fill up with settled sludge after 6.5 hours (assuming 90% of the settled sludge volume is water). Thus, the whole tube length would fill to that level in 38 hours, i.e., back flushing must take place at least once in 38 hours.

CONCLUSIONS

In recent years, many systems have been proposed to improve the performance or increase the capacities of existing water and wastewater treatment facilities. Shallow-depth clarification through the use of the tube settlers is one of these systems. The study described herein was devoted to clarifying some of the unsettled questions about tube settlers. The following conclusions were reached.

From the Theoretical Study

1. A theoretical model for predicting the performance of circular (or hexagonal) tube settlers taking into consideration the effect of the velocity profile variations from uniform at the tube entrance to a fully developed laminar flow profile at the end of the transition length was established. This model is called the Fadel model.
2. The model can be used in three different ways:
 - a) The model has been written in Fortran language for solution on a VAXA computer system. (See Appendix A).
 - b) Model output converted into design charts. Five charts were constructed for predicting the performance of 2-, 3-, 4-, 5-, and 6-inch diameter tubes. The designer must first establish an average tube flow velocity, the minimum settling velocity of the particle to be removed, the degree of tube inclination and the tube diameter. He may then obtain the required tube settler length from the chart.

- c) An equation (30) which approximates the results obtained with the Fadel model may be used; however, the designer must establish the same five values as in b) to use the equation.
3. An assumption was made to predict the performance of an essentially horizontal tube under conditions of sludge build up on the tube bottom. A 40% storage depth for sludge accumulation was set as the maximum safe limit based on the assumption.
 4. An inlet and outlet arrangement for the essentially horizontal tube sedimentation tank was proposed.

From the Experimental Study

1. The experimental work demonstrated the validity of the Fadel model as a method of determining the settling length required in circular tube settlers. This is the first time experimental work has succeeded in verifying the performance of a tube settler using a design model.
2. The experimental work showed that the limit for the allowable maximum flow velocity through tube settler is much higher than the limits recommended in the literature. An average flow velocity of up to 5 fpm was used with no observed sweepout of settled particles.
3. Uniformly sized particles were collected in the cups of the laboratory tube settlers. If all particles have the same shape, this procedure may be used to obtain uniform particle size diameters under the specified conditions. The

experimental equipment is economical to build and easy and fast to operate.

4. Both the essentially-horizontal and the steeply inclined tubes can be designed using the Fadel model.
5. For circular tubes, a maximum allowable storage depth of 40% of the tube diameter is recommended. The experimental work indicated that a sludge depth up to 53% of the tube diameter can be attained, without resulting in failure of tube performance. However, in design, tube settlers should be cleaned when the sludge accumulation reaches 40% of the tube diameter.

RECOMMENDATIONS

The following recommendations for further work were suggested in the course of both the experimental and the theoretical studies conducted for evaluating tube settler performance:

1. Regularly shaped tube settlers, i.e., square, rectangular, etc., need to be theoretically and experimentally studied using the procedures described in this dissertation.
2. Irregular shapes (like the sixth shape in Figure 8, and the shape proposed by Willis, Figure 29) have no theoretically studied velocity profiles, and will need to be investigated using the same experimental method.
3. A pilot plant should be established to determine the best inlet and outlet arrangements for both tube settler configurations. For example, such a plant could employ the arrangement proposed for essentially horizontal tubes by Fadel, and proposed for steeply inclined tubes by Willis.
4. It is recommended that the experimental method be examined as a device for separating uniform-size particles using other particle shapes. Also, this experimental method may be used to determine the shape factor for different particles shapes by comparing their settling velocities with those obtained from the spherical glass beads.

REFERENCES

1. Beyer, William H. ICRC Standard Mathematical Tables. 26th edition. Boca Raton, Florida, CRC Press, Inc., 1981.
2. Camp, Thomas R. A Study of the Rational Design of Settling Tanks, *Journal of Sewage Works* 8:742-758, June 1936.
3. Camp, Thomas R. Studies of Sedimentation Basin Design. *Journal of Sewage and Industrial Wastes* 25:1-12, 1953.
4. Camp, Thomas R. Sedimentation and the Design of Settling Tanks. *Transaction, American Society of Civil Engineering*, Vol. 3, pages 895-936, April, 1945.
5. Culp, G. L. and S. P. Hansen. Applying Shallow Depth Sedimentation Theory. *Journal of the American Water Works Association* 59:1134-1148, Sept., 1967.
6. Culp, G. L., S. Hansen, and G. Richardson. High Rate Sedimentation in Water Treatment Works. *Journal of the American Water Works Association* 60:681-698, June, 1968.
7. Dick, R. I. Fundamental Aspects of Sedimentation. *Journal of Water and Wastes Engineering* 6:45-50, February, 1969.
8. El-Baroudi, H. M. and D. R. Fuller. Tracer Dispersion of High Rate Settling Tanks. *Journal of American Society of Civil Engineering*, 99 (EE3):347-369, June, 1973.
9. Fair, G. M., J. C. Gleyer, and D. A. Okum. *Water and Wastewater Engineering. Volume 2. Water Purification and Waste Water Treatment and Disposal.* New York: Wiley and Sons, 1968.
10. Fischerstrom, C. N. H. Sedimentation in Rectangular Basins. *Proceedings of the American Society of Civil Engineering, Journal of Sanitary Engineering Division*, pages 325-339, May, 1955.
11. Hanke, E. F. and F. Lssch. *Tables of Higher Functions.* 6th edition. New York: McGraw Hill, 1960.
12. Hernandez, John W. and John R. Wright. Design Parameters for Tube-Settlers. *Purdue Proceedings of the 25th Industrial Waste Conference*, May, 1970. *Engineering Extension Series No. 137, Part 2*, pages 805-829.
13. King, Williams H. and Ernest F. Brater. *Handbook of Hydraulics for the Solution of Hydraulic Engineering Problems.* New York: McGraw-Hill, 1976.

14. Kreyszig, E. Advanced Engineering Mathematics. Third edition, New York: Wiley, 1972.
15. Langhaar, H. L. Steady Flow in the Transition Length of a Straight Tube. Journal of Applied Mechanics, A:55-58, June, 1942.
16. Langhaar, H. L. Dimensional Analysis and Theory of Models. New York: John Wiley and Sons, 1960.
17. Metcalf and Eddy. Wastewater Engineering: Treatment Disposal Reuse. New York: McGraw Hill, 1979.
18. Rouse, Hunter. Engineering Hydraulics. New York: John Wiley & Sons, Inc., 1950.
19. Schlichting, H. Boundary-layer Theory. Sixth edition. New York: McGraw Hill, 1968.
20. Slechta, A. F., and Walter R. Conley. Recent Experience in Plant-Scale Application of the Settling Tube Concept. Journal of Water Pollution Control Federation 43(8):1724-1738, December, 1971.
21. Szymanski, V. Sur L'ecoulement Non Permanent Du Fluide Visqueux Dans Le Tuyau. Proceedings of the International Congress of Applied Mechanics, Stockholm I:249-254, April, 1930.
22. Van Vliet, B. M. The Efficiency of Inclined Tube and Plate Modules in a High Line Clarification Process. Journal of Water Research, 11:783-788, 1977.
23. Verhoff, F. H. Optimal Design of High Rate Sedimentation Devices. J. ASCE, 105(E2):199-215, April, 1979.
24. White, M. F. Fluid Mechanics. New York: McGraw Hill. 1979.
25. Willis, R. M. Tubular Settlers - A Technical Review. Journal of the American Water Works Association 59:331-335, June, 1978.
26. Yao, Kuan M. Column Settling Test and Tube Settling. Journal of American Water Work Association, 71:109-112, February, 1979.
27. Yao, Kuan M. Theoretical Study of High Rate Sedimentation. Journal of the Water Pollution Control Federation 42(2, Part 1):218-228, February, 1970.
28. Yao, Kuan M. Design of High Rate Settlers, Journal of the Environmental Engineering Division, ASCE, 99(E5):621-637, February, 1973.

ACKNOWLEDGEMENTS

The studies described in this dissertation were funded in part by the Engineering Research Institute, which the author was funded by and also an Egyptian Mission Fellowship.

The author wishes to express his appreciation to his many associates who contributed to the author's work.

- To Dr. E. Robert Baumann, who served as my major professor and provided research guidance and technical advice as well as moral support.
- To Dr. C. S. Oulman for his guidance, encouragement, and very helpful suggestions during the course of study,
- To Dr. T. A. Astin for his encouragement and moral support.
- To Drs. Dennis Johnson and Homer Walker for their help as members on my committee,
- To my fellow graduate students, Roger V. Stephenson and Adrian Hansen for their good and hard times,
- To Rebecca Shivvers, not only for her fast, efficient typing, but also for her helpful suggestions in editing the dissertation.

Also, I want to express a very special appreciation to members of my family without whose support I would not have found this study so satisfying to me.

- To my wife, Rawia, and my sons, Ahmed, Maysara, and Hatem, who were understanding and patient with me in spite of the long periods I had to be away from them while doing my research, studying, and writing this dissertation.

- To my mother, my sisters, Rawia and Rabha, and my brother, Maysara, for their continued support and encouragement during my graduate studies.

Finally, I want to thank all the Egyptian employees in the Egyptian Mission Bureau in Washington, D.C. and Cairo, Egypt for their faithful cooperation and fast efficient work.

APPENDIX A. COMPUTER PROGRAM

```

INTEGER Z,Y,N,M
CHARACTER*1 RESP
CHARACTER*1 CHOICE
CHARACTER*80 TITLE
CHARACTER*50 GTITLE
REAL A(20),THETA(20),VAV(20),VSC(20),NU(20),LAMBDA(21,31)
REAL V(21,30),SIGMA(31),D,LM1,LM2,SH,YH,DEG,VISC
REAL XTOT,TTOT,DCTOT,X(30),DA,V1(30),V2(30),V3(30),V4(30)
REAL V2P(31),V3P(31),V4P(31),V2DP(31),V3DP(31),V4DP(31)
REAL VP,T(30),DC(30),VSCV(20),L,LR,LS,LC,LW,VSCH(20),TL,LM
LOGICAL SAMINC , AGRPH
PI=3.14159

C
C NAME OUTPUT FILE: TUBEMD.OUT
C
      OPEN (UNIT=99, FILE='TUBEMD.OUT',STATUS='NEW')
C ENTER PROBLEM TITLE
C
      WRITE(6,*)( ' DO YOU WISH TO HAVE A DATA FILE PREPARED FOR
+ LATER USE OF AGRAPH ? ( YES=Y, NO=ANY KEY ) ' )
      READ(*,600,ERR=800,END=900) RESP
      IF (RESP .EQ. 'Y' .OR. RESP .EQ. 'y') THEN
          WRITE(15,*)( ' -1000 1 ' )
          AGRPH = .TRUE.
      ELSE
          AGRPH = .FALSE.
      END IF

C
C READ DEPTH VS. LAMBDA TABLE FROM INPUT FILE=FORO10.DAT
C
      DO 10 I=1,21
          READ(10,*,ERR=800,END=900)(LAMBDA(I,K),K=1,7)
          READ(10,*,ERR=800,END=900)(LAMBDA(I,K),K=8,13)
          READ(10,*,ERR=800,END=900)(LAMBDA(I,K),K=14,19)
          READ(10,*,ERR=800,END=900)(LAMBDA(I,K),K=20,25)
          READ(10,*,ERR=800,END=900)(LAMBDA(I,K),K=26,31)
      10 CONTINUE

C
C READ SIGMA TABLE FROM INPUT FILE: FORO11.DAT
C
      READ(11,*,ERR=800,END=900)(SIGMA(J),J=1,30)

C
C READ INPUT DATA
C
      WRITE(6,119)
      119 FORMAT('1  ' /
+ ' ***** ' /
+ ' * ' /

```

```

+ / *      CHOOSE ONE OF THE FOLLOWING OPTIONS : */
+ / *      */
+ / * 1- SOLVE FOR DEPTH VS. SETTLING LENGTH (LS) */
+ / * 2- SOLVE FOR DIAMETER VS. LS      */
+ / * 3- SOLVE FOR THETA VS. LS      */
+ / * 4- SOLVE FOR AVERAGE VELOCITY (VAV) VS. LS */
+ / * 5- SOLVE FOR SETTLING VELOCITY (VSC) VS LS */
+ / * 6- SOLVE FOR KIN. VISCOSITY (NU) VS. LS */
+ / *      */
+ / ***** */)
READ(*,600,ERR=800,END=900) CHOICE
IF ( CHOICE .NE. '1' ) THEN
  WRITE (6,120)
120  FORMAT(/' HOW MANY VALUES OF ( DIA,THETA,VAV,VSC,OR NU)'/
+      ' DO YOU WANT TO SOLVE FOR ? ( ENTER A NUMBER BETWEEN
+ 2 AND 20 )'/)
READ(*,602,ERR=800,END=900) NR
602  FORMAT(I2)
END IF
IF(CHOICE.EQ.'1')THEN
  WRITE(6,*)(' ENTER DIAMETER OF PIPE IN INCHES :')
  READ(*,*,ERR=800,END=900)A(1)
  A(1)=A(1)/24.
  WRITE(6,*)(' ENTER THETA IN DEGREES :')
  READ(*,*,ERR=800,END=900)THETA(1)
  THETA(1)=THETA(1)*3.14159/180.
  WRITE(6,*)(' ENTER VAV IN FEET PER MINUTE :')
  READ(*,*,ERR=800,END=900)VAV(1)
  WRITE(6,*)(' ENTER VSC IN FEET PER MINUTE :') .
  READ(*,*,ERR=800,END=900)VSC(1)
  WRITE(6,*)(' ENTER NU IN FEET SQUARE PER SEC :')
  READ(*,*,ERR=800,END=900)NU(1)
  NU(1)=NU(1)*60.0
  DO 151 K=1,NR
    A(K) =A(1)
    THETA(K)=THETA(1)
    VAV(K) =VAV(1)
    VSC(K) =VSC(1)
    NU(K) =NU(1)
151  CONTINUE
    VSCV(K)=(VSC(K))*COS(THETA(K))
    VSCH(K)=(VSC(K))*SIN(THETA(K))
    VSCV(K)=VSCV(1)
    VSCH(K)=VSCH(1)
  ELSE IF (CHOICE .EQ. '2') THEN
    WRITE(6,*)(' ENTER VALUES OF DIAMETER IN INCHES :')
    READ(*,*,ERR=800,END=900) ( A(K), K=1,NR )
    DO 235 K=1,NR

```



```

      A(K)=A(K)/24.0
235  CONTINUE
      WRITE(6,*)(` ENTER THETA IN DEGREES :`)
      READ(*,*,ERR=800,END=900)THETA(1)
      THETA(1)=THETA(1)*3.14159/180.
      WRITE(6,*)(` ENTER VAV IN FEET PER MINUTE :`)
      READ(*,*,ERR=800,END=900)VAV(1)
      WRITE(6,*)(` ENTER VSC IN FEET PER MINUTE :`)
      READ(*,*,ERR=800,END=900)VSC(1)
      WRITE(6,*)(` ENTER NU IN FEET SQUARE PER SEC :`)
      READ(*,*,ERR=800,END=900)NU(1)
      NU(1)=NU(1)*60.0
      DO 152 K=1,NR
          THETA(K)=THETA(1)
          VAV(K)  =VAV(1)
          VSC(K)  =VSC(1)
          NU(K)   =NU(1)
152  CONTINUE
      DO 161 K=1,NR
          VSCV(K) =(VSC(K))*COS(THETA(K))
          VSCH(K) =(VSC(K))*SIN(THETA(K))
161  CONTINUE
      ELSE IF(CHOICE.EQ.`3`) THEN
          WRITE(6,*)(` ENTER DIAMETER OF PIPE IN INCHES :`)
          READ(*,*,ERR=800,END=900)A(1)
          A(1)=A(1)/24.
          WRITE(6,*)(` ENTER VALUES OF THETA IN DEGREES :`)
          READ(*,*,ERR=800,END=900) ( THETA(K),K=1,NR)
          DO 236 K=1,NR
              THETA(K)=THETA(K)*3.1416/180.0
236  CONTINUE
          WRITE(6,*)(` ENTER VAV IN FEET PER MINUTE :`)
          READ(*,*,ERR=800,END=900)VAV(1)
          WRITE(6,*)(` ENTER VSC IN FEET PER MINUTE :`)
          READ(*,*,ERR=800,END=900)VSC(1)
          WRITE(6,*)(` ENTER NU IN FEET SQUARE PER SEC :`)
          READ(*,*,ERR=800,END=900)NU(1)
          NU(1)=NU(1)*60.0
          DO 153 K=1,NR
              A(K)  =A(1)
              VAV(K) =VAV(1)
              VSC(K) =VSC(1)
              NU(K)  =NU(1)
153  CONTINUE
          DO 162 K=1,NR
              VSCV(K) =(VSC(K))*COS(THETA(K))
              VSCH(K) =(VSC(K))*SIN(THETA(K))
162  CONTINUE

```

```

ELSE IF(CHOICE.EQ.'4') THEN
  WRITE(6,*)(` ENTER DIAMETER OF PIPE IN INCHES :`)
  READ(*,*,ERR=800,END=900)A(1)
  A(1)=A(1)/24.
  WRITE(6,*)(` ENTER THETA IN DEGREES :`)
  READ(*,*,ERR=800,END=900)THETA(1)
  THETA(1)=THETA(1)*3.14159/180.
  WRITE(6,*)(` ENTER VALUES OF VAV IN FEET PER MINUTE :`)
  READ(*,*,ERR=800,END=900) (VAV(K),K=1,NR)
  WRITE(6,*)(` ENTER VSC IN FEET PER MINUTE :`)
  READ(*,*,ERR=800,END=900)VSC(1)
  WRITE(6,*)(` ENTER NU IN FEET SQUARE PER SEC :`)
  READ(*,*,ERR=800,END=900)NU(1)
  NU(1)=NU(1)*60.0
  DO 154 K=1,NR
    A(K) =A(1)
    THETA(K)=THETA(1)
    VSC(K) =VSC(1)
    NU(K)  =NU(1)
154  CONTINUE
  DO 163 K=1,NR
    VSCV(K) =(VSC(K))*COS(THETA(K))
    VSCH(K) =(VSC(K))*SIN(THETA(K))
163  CONTINUE
ELSE IF(CHOICE.EQ.'5')THEN
  WRITE(6,*)(` ENTER DIAMETER OF PIPE IN INCHES :`)
  READ(*,*,ERR=800,END=900)A(1)
  A(1)=A(1)/24.
  WRITE(6,*)(` ENTER THETA IN DEGREES :`)
  READ(*,*,ERR=800,END=900)THETA(1)
  THETA(1)=THETA(1)*3.14159/180.
  WRITE(6,*)(` ENTER VAV IN FEET PER MINUTE :`)
  READ(*,*,ERR=800,END=900)VAV(1)
  WRITE(6,*)(` ENTER VALUES OF VSC IN FEET PER MINUTE :`)
  READ(*,*,ERR=800,END=900) (VSC(K),K=1,NR)
  WRITE(6,*)(` ENTER NU IN FEET SQUARE PER SEC :`)
  READ(*,*,ERR=800,END=900)NU(1)
  NU(1)=NU(1)*60.0
  DO 155 K=1,NR
    A(K) =A(1)
    THETA(K)=THETA(1)
    VAV(K) =VAV(1)
    NU(K)  =NU(1)
155  CONTINUE
  DO 164 K=1,NR
    VSCV(K) =(VSC(K))*COS(THETA(K))
    VSCH(K) =(VSC(K))*SIN(THETA(K))
164  CONTINUE

```

```

ELSE IF(CHOICE.EQ.'6') THEN
  WRITE(6,*)(' ENTER DIAMETER OF PIPE IN INCHES :')
  READ(*,*,ERR=800,END=900)A(1)
  A(1)=A(1)/24.
  WRITE(6,*)(' ENTER THETA IN DEGREES :')
  READ(*,*,ERR=800,END=900)THETA(1)
  THETA(1)=THETA(1)*3.14159/180.
  WRITE(6,*)(' ENTER VAV IN FEET PER MINUTE :')
  READ(*,*,ERR=800,END=900)VAV(1)
  WRITE(6,*)(' ENTER VSC IN FEET PER MINUTE :')
  READ(*,*,ERR=800,END=900)VSC(1)
  WRITE(6,*)(' ENTER VALUES OF NU IN FEET SQUARE PER SEC:')
  READ(*,*,ERR=800,END=900)(NU(K),K=1,NR)
  DO 239 K=1,NR
    NU(K)=NU(K)*60.0
239  CONTINUE
  DO 156 K=1,NR
    A(K) =A(1)
    THETA(K)=THETA(1)
    VAV(K) =VAV(1)
    VSC(K) =VSC(1)
156  CONTINUE
    DO 165 K=1,NR
      VSCV(K) =(VSC(K))*COS(THETA(K))
      VSCH(K) =(VSC(K))*SIN(THETA(K))
165  CONTINUE
  END IF
  WRITE(6,*)(' ENTER WATER TEMP IN DEG F :')
  READ(*,*,ERR=800,END=900)TEMP
  IF(CHOICE.EQ.'1') NR=1
C
C INITIALIZE DISTANCE SUM, TIME SUM, CALCULATED DEPTH SUM, & LOGICAL
C
C
C HEADING OF OUTPUT TABLE
C
  IF(CHOICE.EQ.'1')THEN
    PRINT *, 'DIAMETER = ',24*A(L),' IN.'
736  FORMAT(F3.1)
    PRINT *, ' THETA = ',THETA(1),' DEG.'
737  FORMAT(F4.1)
    PRINT *, ' AVERAGE VELOCITY = ',VAV(1),' FPM'
738  FORMAT(F5.3)
    PRINT *, ' SETTLING VELOCITY = ',VSC(1), 'FPS'
739  FORMAT(F5.3)
    PRINT *, ' KINEMATIC VISCOSITY = ',NU(1),' SQ.FT/S'
740  FORMAT(F10.8)
    WRITE(6,200)

```

```

WRITE(6,650)
WRITE(99,200)
WRITE(99,650)
ELSE
WRITE(99,741)
741  FORMAT('1',5X,'DIAM.',4X,'VAV',5X,'VSC',4X,'TEMP.',3X,
+      'K. VISCOSITY',3X,'THETA',3X,'SET. LENGTH')
WRITE(99,742)
742  FORMAT(6X,'-----')
+-----')
WRITE(99,743)
743  FORMAT(6X,'IN.',5X,'FPM',7X,'FPM',5X,'F',7X,'SQ.FT/SEC',5X,
+      'DEG.',5X,'FEET')
WRITE(99,742)
WRITE(99,745)
WRITE(6,741)
WRITE(6,742)
WRITE(6,743)
WRITE(6,745)
END IF
C
C SOLVE FOR THE TIME, DISTANCE, AND DEPTH SUMS OF PARTICLE AT EACH
C SECTION
DO 100 L=1,NR
XTOT=0
TTOT=0
DCTOT=0
SAMINC =.FALSE.
DO 101 I=1,21
LAMBDA(I,1)=LAMBDA(I,1)*A(L)
101  CONTINUE
DO 30 I=1,21
DO 20 K=2,31
V(I,(K-1))=VAV(L)*(LAMBDA(I,K))-VSCH(L)
20  CONTINUE
30  CONTINUE
DO 50 J=1,29
C FIND WIDTH OF EACH SECTION
X(J)=((SIGMA(J+1)-SIGMA(J))*(VAV(L)-VSCH(L))*A(L)**2)/NU(L)
C ASSUME DEPTH OF THE PARTICLE FOR SECTION
DA=0.10*A(L)
C SOLUTION
400  IF(J.EQ.1)THEN
V1(J)=VAV(L)
V2(J)=0
V3(J)=VAV(L)
V4(J)=DA*V(2,2)/(0.10*A(L))
ELSE

```

```

V1(J)=V4(J-1)
Z      =INT(DCTOT/(0.10*A(L)))
Y      =Z+1
N      =INT((DCTOT+DA)/(0.10*A(L)))
M      =N+1
IF(DCTOT.GE.(N*0.1*A(L)).AND.DCTOT.LE.(M*0.1*A(L)).AND.(DCTOT+DA)
+ .GE.(N*0.1*A(L)).AND.(DCTOT+DA).LE.(M*0.1*A(L)))THEN
SAMINC=.TRUE.
ELSE
SAMINC=.FALSE.
END IF
IF(SAMINC.EQ..TRUE..AND.N.EQ.0)THEN
V2DP(J)=V(2,(J+1))
V3DP(J)=V(2,J)
V4DP(J)=V(2,(J+1))
V2(J)  =V2DP(J)*DCTOT/(0.10*A(L))
V3(J)  =V3DP(J)*(DCTOT+DA)/(0.10*A(L))
V4(J)  =V4DP(J)*(DCTOT+DA)/(0.10*A(L))
ELSE
Z=Z+1
Y=Y+1
N=N+1
M=M+1
V2P(J) =V(Z,(J+1))
V2DP(J)=V(Y,(J+1))
V3P(J) =V(N,J)
V3DP(J)=V(M,J)
V4P(J) =V(N,(J+1))
V4DP(J)=V(M,(J+1))
+ V2(J)=V2P(J)+(DCTOT-(0.10*A(L)*(Z-1)))*(V2DP(J)-V2P(J))/
(0.10*A(L))
+ V3(J)=V3P(J)+((DCTOT+DA)-(0.10*A(L)*(N-1)))*(V3DP(J)-V3P(J))/
(0.1*A(L))
+ V4(J)=V4P(J)+((DCTOT+DA)-(0.10*A(L)*(N-1)))*(V4DP(J)-V4P(J))/
(0.1*A(L))
END IF
END IF
VP      =(V1(J)+V2(J)+V3(J)+V4(J))/4.0
T(J)    =X(J)/VP
DC(J)   =T(J)*VSCV(L)
XTOT    =XTOT+X(J)
TTOT    =TTOT+T(J)
DCTOT   =DCTOT+DC(J)
IF(DCTOT.EQ.2*A(L).AND.CHOICE.EQ.'1')THEN
IF(AGRPH)CALL AGROUT(DCTOT,TTOT,XTOT,A)
CALL OUT(DCTOT,TTOT,XTOT,AGRPH)
GOTO 4000
END IF

```

```

      IF (DCTOT .EQ. 2*A(L) .AND. CHOICE .NE. '1') GOTO 520
IF(DCTOT.GT.(2*A(L)))THEN
      TTOT =TTOT-T(J)
      XTOT =XTOT-X(J)
      TL =(2*A(L)-(DCTOT-DC(J)))/VSCV(L)
      VP =(V1(J)+V2(J))/4.0
      DCTOT = 2*A(L)
      TTOT =TTOT+TL
      XTOT =XTOT+(TL*VP)
      IF (CHOICE .NE. '1') GOTO 520
      IF(CHOICE.EQ.'1') THEN
        IF(AGRPH)CALL AGROUT(DCTOT,TTOT,XTOT,A)
        CALL OUT(DCTOT,TTOT,XTOT,AGRPH)
        GOTO 4000
      END IF
ELSE
      IF((ABS(DC(J)-DA)/DA).LE. 0.01)THEN
        IF(CHOICE.EQ.'1') THEN
          IF(AGRPH)CALL AGROUT(DCTOT,TTOT,XTOT,A)
          CALL OUT(DCTOT,TTOT,XTOT,AGRPH)
        END IF
        SAMINC=.FALSE.
        GOTO 50
      ELSE
        DCTOT=DCTOT-DC(J)
        XTOT= XTOT-X(J)
        TTOT=TTOT-T(J)
        DA=DC(J)
        GOTO 400
      END IF
END IF
50 CONTINUE
      IF(DCTOT.LT.(2*A(L)).AND.CHOICE.EQ.'1')THEN
        S=2*A(1)-DCTOT
        YH=S/(2*A(1))
        LM=8.0*(VAV(1)/VSCV(1))*(YH**2/2.0-YH**3/3.0)-(YH*TAN(THETA(1)))
        LM1=2*A(1)*LM
        XTOT=XTOT+LM1
        DCTOT=2*A(1)
        TTOT=TTOT+S/VSCV(1)
        IF(AGRPH) CALL AGROUT (DCTOT,TTOT,XTOT,A)
        CALL OUT (DCTOT,TTOT,XTOT,AGRPH)
        GOTO 4000
      ELSE IF(DCTOT.LT.(2*A(L)).AND.CHOICE.NE.'1')THEN
        S=2.0*A(L)-DCTOT
        YH=S/(2*A(L))
        LM=8.0*(VAV(L)/VSCV(L))*(YH**2/2.0-YH**3/3.0)-(YH*TAN(THETA(L)))
        LM1=2*A(L)*LM

```

```

      XTOT=XTOT+LM1
      DCTOT=2*A(L)
      TTOT=TTOT+S/VSCV(L)
      GOTO 520
END IF
520  D=24*A(L)
      DEG=180*THETA(L)/3.14159
      VISC=NU(L)/60
      WRITE(6,745)D,VAV(L),VSC(L),TEMP,VISC,DEG,XTOT
      WRITE(99,745)D,VAV(L),VSC(L),TEMP,VISC,DEG,XTOT
745  FORMAT(6X,F3.1,4X,F5.3,5X,F5.3,3X,F4.1,5X,F10.8,4X,F4.1,2X,
+      F6.3)
100  CONTINUE
C PROVIDE OPTION FOR SOLVING THE PROBLEM BY OTHER
C METHODS (YAO,CULP,WILLIS)
4000 IF(CHOICE.EQ.'1')THEN
+ PRINT *, 'DO YOU WISH TO SOLVE THE SAME PROBLEM BY OTHER
+ METHODS ( ENTER Y OR N )'
      READ(*,600,ERR=800,END=900)RESP
      IF(RESP .EQ. 'Y' .OR. RESP .EQ. 'y') THEN
      LR=(0.227*VAV(1)*A(1)**2)/NU(1)
      L =(1.333*VAV(1)/VSC(1)-SIN(THETA(1)))*2*A(1)/COS(THETA(1))
      IF(LR.GE.L)THEN
          LS=2*L
      ELSE
          LS=L+LR
      END IF
      WRITE(6,*)( '          YAO METHOD : ' )
      WRITE(99,*)( '          YAO METHOD : ' )
      WRITE(99,*)( '          ***** ' )
      WRITE(6,*)( '          ***** ' )
      WRITE(99,*)( '          TRANSITION LENGTH = ',LR, ' FT' )
      WRITE(99,*)( '          MODEL LENGTH = ',L, ' FT' )
      WRITE(99,*)( '          SUGGESTED TUBE LENGTH = ',LS, ' FT' )
      WRITE(6,*)( '          TRANSITION LENGTH = ',LR, ' FT' )
      WRITE(6,*)( '          MODEL LENGTH = ',L, ' FT' )
      WRITE(6,*)( '          SUGGESTED TUBE LENGTH = ',LS, ' FT' )
      LC=2*A(1)*(VAV(1)-VSCH(1))/VSCV(1)
      WRITE(6,*)( 'CULP METHOD: ', 'SUGGESTED TUBE LENGTH= ',LC, ' FT' )
      WRITE(99,*)( 'CULP METHOD: ', 'SUGGESTED TUBE LENGTH= ',LC, ' FT' )
      LW=2*A(1)*VAV(1)/VSCV(1)
      WRITE(6,*)( 'WILLIS METHOD: ', 'SUGGESTED TUBE LENGTH= ',LW, ' FT' )
      WRITE(99,*)( 'WILLIS METHOD: ', 'SUGGESTED TUBE LENGTH= ',LW, ' FT' )
      END IF
      END IF
      GOTO 3000
500  FORMAT(A80)
600  FORMAT(A1)

```

```

800  PRINT *, ' ERROR ENCOUNTERED IN ENTERING DATA - START AGAIN '
      GOTO 3000
900  PRINT *, ' END OF FILE ENCOUNTERED IN READING INPUT DATA '
      GOTO 3000
200  FORMAT('1  SETTLING DEPTH(FT)      DETENTION TIME(MIN)      SETTL
+ING LENGTH(FT) ')
650  FORMAT(' -----
+----- ')
201  FORMAT(9X,F6.4,12X,F7.4,12X,F9.4)
3000 CALL EXIT
      END
      SUBROUTINE OUT(DCTOT,TTOT,XTOT,AGRPH)
      REAL DCTOT,TTOT,XTOT
      LOGICAL AGRPH
      WRITE(6,201)DCTOT,TTOT,XTOT
      WRITE(99,201)DCTOT,TTOT,XTOT
201  FORMAT(9X,F6.4,12X,F7.4,12X,F9.4)
      RETURN
      END
      SUBROUTINE AGROUT(DCTOT,TTOT,XTOT,A)
      REAL Y,DCTOT,TTOT,XTOT,A
      CHARACTER*40 GTITLE
      Y = 2*A(L) - DCTOT
      WRITE(15,*) XTOT,Y
      CALL OUT(DCTOT,TTOT,XTOT,AGRAPH)
      RETURN
800  PRINT *, ' ERROR ENCOUNTERED IN ENTERING DATA - START AGAIN '
      GOTO 3333
900  PRINT *, ' END OF FILE ENCOUNTERED IN READING INPUT DATA '

```

File: FOR010.DAT

0.0	0.0	0.0	0.0	0.0	0.0	0.0
	0.0	0.0	0.0	0.0	0.0	0.0
	0.0	0.0	0.0	0.0	0.0	0.0
	0.0	0.0	0.0	0.0	0.0	0.0
	0.0	0.0	0.0	0.0	0.0	0.0
0.1	0.8	0.7459	0.7219	0.6859	0.6462	0.6250
	0.6033	0.5807	0.5575	0.5337	0.5098	0.4859
	0.4628	0.4744	0.4519	0.4410	0.4313	0.4215
	0.4159	0.4103	0.4057	0.4010	0.3981	0.3954
	0.3913	0.3888	0.3863	0.3841	0.3841	0.3821
0.2	1.1079	1.0467	1.0303	1.0093	0.9826	0.9671
	0.9498	0.9310	0.9104	0.8883	0.8649	0.8406
	0.8283	0.8160	0.8036	0.7912	0.7803	0.7693
	0.7629	0.7564	0.7509	0.7454	0.7423	0.7389
	0.7365	0.7340	0.7308	0.7275	0.7258	0.7229
0.3	1.1079	1.1603	1.1626	1.1626	1.1586	1.1548
	1.1497	1.1430	1.1346	1.1244	1.1125	1.0989
	1.0917	1.0845	1.0767	1.0689	1.0618	1.0547
	1.0502	1.0456	1.420	1.0383	1.0353	1.0336
	1.0319	1.302	1.0276	1.0249	1.0237	1.0219
0.4	1.1079	1.2047	1.2198	1.2357	1.2511	1.2548
	1.2654	1.2718	1.2772	1.2817	1.2850	1.2871
	1.2874	1.2876	1.2874	1.2873	1.2869	1.2865
	1.2857	1.2848	1.2843	1.2838	1.2835	1.2833
	1.2823	1.2827	1.2818	1.2808	1.2805	1.2802
0.5	1.1079	1.2222	1.2447	1.2708	1.3	1.3159
	1.3327	1.3502	1.3681	1.3865	1.4049	1.4229
	1.4317	1.4405	1.4486	1.4566	1.4642	1.4718
	1.4752	1.4788	1.4821	1.4856	1.4870	1.4891
	1.4911	1.4930	1.4936	1.4941	1.4956	1.4978
0.6	1.1079	1.2292	1.2557	1.2877	1.3260	1.3479
	1.3719	1.3979	1.4258	1.4558	1.4873	1.52
	1.5366	1.5532	1.5694	1.5855	1.6009	1.6163
	1.6242	1.6320	1.6393	1.6466	1.6506	1.6550
	1.6591	1.6632	1.6652	1.6671	1.6712	1.6756
0.7	1.1079	1.2320	1.2605	1.2944	1.3398	1.3675
	1.3945	1.4266	1.4620	1.5008	1.5428	1.5874
	1.6106	1.6337	1.6568	1.6789	1.7022	1.7245
	1.7361	1.7476	1.7587	1.7697	1.7759	1.7818
	1.7881	1.7944	1.7977	1.8009	1.8060	1.8130
0.8	1.1079	1.2331	1.2627	1.3	1.3470	1.3752
	1.4072	1.4452	1.4833	1.5288	1.5782	1.6315
	1.6596	1.6876	1.7159	1.7442	1.7718	1.7994
	1.8076	1.8158	1.8361	1.8563	1.8641	1.8717
	1.8795	1.8873	1.8921	1.8969	1.9032	1.9116
0.9	1.1079	1.2336	1.2636	1.3017	1.3504	1.38
	1.4137	1.4520	1.4953	1.5440	1.5978	1.6564
	1.6874	1.7183	1.7501	1.7816	1.8126	1.8435

	1.8601	1.8767	1.8923	1.9078	1.9255	1.9265
	1.9340	1.9425	1.9482	1.9538	1.9680	1.9745
1.0	1.1079	1.2337	1.2638	1.3022	1.3514	1.3814
	1.4157	1.4547	1.4989	1.5488	1.6041	1.6645
	1.6965	1.7286	1.7613	1.7939	1.8260	1.858
	1.8753	1.8923	1.9000	1.9249	1.9342	1.9432
	1.9521	1.9609	1.9668	1.9727	1.98	1.99
1.1	1.1079	1.2336	1.2636	1.3017	1.3504	1.38
	1.4137	1.4520	1.4953	1.5440	1.5978	1.6564
	1.6874	1.7183	1.7501	1.7816	1.8126	1.8435
	1.8601	1.8767	1.8923	1.9078	1.9255	1.9265
	1.9340	1.9425	1.9482	1.9538	1.9680	1.9745
1.2	1.1079	1.2331	1.2627	1.3	1.3470	1.3752
	1.4072	1.4452	1.4833	1.5288	1.5782	1.6315
	1.6596	1.6876	1.7159	1.7442	1.7718	1.7994
	1.8076	1.8158	1.8361	1.8563	1.8641	1.8717
	1.8795	1.8873	1.8921	1.8969	1.9032	1.9116
1.3	1.1079	1.2320	1.2605	1.2944	1.3398	1.3675
	1.3945	1.4266	1.4620	1.5008	1.5428	1.5874
	1.6106	1.6337	1.6568	1.6789	1.7022	1.7245
	1.7361	1.7476	1.7587	1.7697	1.7759	1.7818
	1.7881	1.7944	1.7977	1.8009	1.8060	1.8130
1.4	1.1079	1.2292	1.2557	1.2877	1.3260	1.3479
	1.3719	1.3979	1.4258	1.4558	1.4873	1.52
	1.5366	1.5532	1.5694	1.5855	1.6009	1.6163
	1.6242	1.6320	1.6393	1.6466	1.6506	1.6550
	1.6591	1.6632	1.6652	1.6671	1.6712	1.6756
1.5	1.1079	1.2222	1.2447	1.2708	1.3	1.3159
	1.3327	1.3502	1.3681	1.3865	1.4049	1.4229
	1.4317	1.4405	1.4486	1.4566	1.4642	1.4718
	1.4752	1.4788	1.4821	1.4856	1.4870	1.4891
	1.4911	1.4930	1.4936	1.4941	1.4956	1.4978
1.6	1.1079	1.2047	1.2198	1.2357	1.2511	1.2548
	1.2654	1.2718	1.2772	1.2817	1.2850	1.2871
	1.2874	1.2876	1.2874	1.2873	1.2869	1.2865
	1.2857	1.2848	1.2843	1.2838	1.2835	1.2833
	1.2823	1.2827	1.2818	1.2808	1.2805	1.2802
1.7	1.1079	1.1603	1.1626	1.1626	1.1586	1.1548
	1.1497	1.1430	1.1346	1.1244	1.1125	1.0989
	1.0917	1.0845	1.0767	1.0689	1.0618	1.0547
	1.0502	1.0456	1.420	1.0383	1.0353	1.0336
	1.0319	1.302	1.0276	1.0249	1.0237	1.0219
1.8	1.1079	1.0467	1.0303	1.0093	0.9826	0.9671
	0.9498	0.9310	0.9104	0.8883	0.8649	0.8406
	0.8283	0.8160	0.8036	0.7912	0.7803	0.7693
	0.7629	0.7564	0.7509	0.7454	0.7423	0.7389
	0.7365	0.7340	0.7308	0.7275	0.7258	0.7229
1.9	0.8	0.7459	0.7219	0.6859	0.6462	0.6250

	0.6033	0.5807	0.5575	0.5337	0.5098	0.4859
	0.4628	0.4744	0.4519	0.4410	0.4313	0.4215
	0.4159	0.4103	0.4057	0.4010	0.3981	0.3954
	0.3913	0.3888	0.3863	0.3841	0.3841	0.3821
2.0	0.0	0.0	0.0	0.0	0.0	0.0
	0.0	0.0	0.0	0.0	0.0	0.0
	0.0	0.0	0.0	0.0	0.0	0.0
	0.0	0.0	0.0	0.0	0.0	0.0

File: FOR011.DAT

0.0
0.00082
0.00418
0.00541
0.0072
0.00997
0.01188
0.0143
0.0174
0.0214
0.0267
0.0335
0.0426
0.0483
0.0549
0.0625
0.0715
0.0821
0.0947
0.1034
0.1132
0.1241
0.1365
0.1459
0.1560
0.1671
0.1795
0.1934
0.2091
0.2270
0.2430

APPENDIX B: NUMERICAL SOLUTION OF FADEL'S MODEL

The required steps for the model are calculated below:

1. Assume:

- 1- Diameter = 2"
- 2- Average flow velocity, V_{av} = 2.88 fpm
- 3- Particle settling velocity, V_{sc} = 0.0742 fpm
- 4- Kinematic viscosity, = 1×10^{-5} ft²/sec
- 5- Tube length = unlimited

Reynolds number = $V_{av} \times D/4$

$$= \frac{2.88 \text{ fpm} \times 2" \times (1 \text{ ft}/12 \text{ in})}{4 \times 1 \times 10^{-5} \text{ ft}^2/\text{sec} \times (60 \text{ sec}/\text{min})} = 200 < 500$$

laminar flow condition.

2. Calculate velocity profiles:

Sample section velocity profiles were calculated using Eq. (19) and Table 4.

Profile of section I:

From Table 4: $\sigma = 0.00082$, $\gamma = 20$:

The hyperbolic Bessel function of 0. order and 2nd order for values higher than 10 are not available in the literature. Accordingly, the velocity profile for this section was established by direct measuring from Figure 34.

$q = \frac{r}{a}$	λ
0	1.1079
0.1	1.1079
0.2	1.1079

0.3	1.1079
0.4	1.1079
0.5	1.1079
0.6	1.1079
0.7	1.1079
0.8	1.1079
0.9	0.8000

Profile of section II:

From Table 4:

	$\sigma = 0.00418$	$\gamma = 10$	
From Reference [11]	$I_0(\gamma) = 2816$	$I_2(10) = 2281.75$	
$q = \frac{r}{a}$	q	$I_0(\gamma q)$	
		λ^*	
0.0	0	1	1.2337
0.1	1	1.2661	1.2336
0.2	2	2.2800	1.2331
0.3	3	4.8810	1.2320
0.4	4	11.3020	1.2292
0.5	5	27.2400	1.2222
0.6	6	67.2300	1.2047
0.7	7	168.5900	1.1603
0.8	8	427.6000	1.0467
0.9	9	1093.6000	0.7549

* λ was calculated using Eq. (9).

Profile of section III:

From Table 4:

	$\sigma = 0.00541$		$\gamma = 9$
From Reference [11]	$I_0(\gamma) = 1093.6$		$I_2(9) = 864.535$
$q = \frac{r}{a}$	q	$I_0(\gamma q)$	λ^*
0.0	0.0	1	1.2638
0.1	0.9	1.2130	1.2636
0.2	1.8	1.9900	1.2627
0.3	2.7	3.8420	1.2607
0.4	3.6	8.0280	1.2557
0.5	4.5	17.4800	1.2447
0.6	5.4	39.0100	1.2198
0.7	6.3	88.4600	1.1626
0.8	7.2	202.9000	1.0303
0.9	8.1	469.5000	0.7219

The remaining velocity profiles can be found in Appendix A, file FOR010.DAT.

3. The distance between two adjacent profiles is calculated using Eq. (20) as

$$L = (\sigma_{i+1} - \sigma_i) a^2 V_{av}/4 .$$

Thus, the distance between section I and II is:

$$\begin{aligned} &= (0.00082 - 0) (1/12)^2 \times 2.88 \text{ fpm}/4 \times 0.00060 \text{ ft}^2/\text{min} \\ &= (0.00082 - 0) \times 33.33 = 0.027 \text{ ft} , \end{aligned}$$

and the distance between section II and III is:

$$= (0.00722 - 0.00082) \times 33.33 = 0.213 \text{ ft} ,$$

and so on. The remaining distances between the other sections can be calculated in the same manner.

4. To follow the particle path through the tube, using the ten steps of the model (page 63).

a) From tube entrance to section II.

First trial:

$$\text{Assume } X = 0.05 D = 0.05 \times 2''/12 = 0.00833 \text{ ft}$$

$$VI = V_{av} = 2.88 \text{ fpm}$$

$$VII = 0 \times 2.88 = 0 \text{ fpm}$$

$$VI' = V_{av} = 2.88 \text{ fpm}$$

$$VII' = 0.9 \times V_{av} = 0.9 \times 2.88 = 2.592 \text{ fpm}$$

$$V_{av} = (2.88 + 0 + 2.88 + 2.592)/4 = 2.088 \text{ fpm}$$

The time required for the particle to travel from the entrance to section I is calculated as::

$$t = 0.00833 \text{ ft}/2.088 \text{ fpm} = 0.0129 \text{ min.}$$

Actual settling depth:

$$X_a = 0.0129 \text{ min} \times 0.0742 \text{ fpm} = 0.000959 \text{ ft}$$

$0.05 D \gg 0.000959$, a second trial is required.

Second trial:

Reassume $X = 0.000959 \text{ ft} = X_a$ from the first trial

$$VI = 2.88 \text{ fpm}$$

$$VII = 0 \text{ fpm}$$

$$VI' = 2.88 \text{ fpm}$$

$$\begin{aligned} VII' &= 0.9 \times 0.000959 \text{ ft} \times 2.88 \text{ fpm}/0.00083 \text{ ft} \\ &= 0.3 \text{ fpm} \end{aligned}$$

$$V_{av} = (2.88 + 0 + 2.88 + 0.3)/4 = 1.51 \text{ fpm}$$

$$t = 0.00833 \text{ ft}/1.51 \text{ fpm} = 0.0177 \text{ min}$$

$$X_a = 0.0177 \text{ min} \times 0.0742 \text{ fpm} = 0.00132 \text{ ft}$$

X assumed \ll X_a calculated, a third trial is required.

Third trial:

Reassume $X = 0.00132 \text{ ft} = X_a$ from the second trial

$$VI = 2.88 \text{ fpm}$$

$$VII = 0 \text{ fpm}$$

$$VI' = 2.88 \text{ fpm}$$

$$\begin{aligned} VII' &= 0.9 \times 0.00132 \text{ ft} \times 2.88 \text{ fpm} \times 0.00132 \text{ ft} \\ &= 0.41 \text{ fpm} \end{aligned}$$

$$V_{av} = (2.88 + 0 + 2.88 + 0.41)/4 = 1.54 \text{ fpm}$$

$$t = 0.00833 \text{ ft}/1.54 \text{ fpm} = 0.0175 \text{ min}$$

$$X_a = 0.0175 \text{ min} \times 1.54 \text{ fpm} = 0.00130 \text{ ft}$$

Because X assumed is approximately equal to the value calculated $(1 + 0.05) X_a$, then the particle will travel from section II to section III starting at a depth equal to 0.0013 ft from the tube invert; the distance from the tube entrance is 0.00833 ft.

b) From section II to section III

First trial:

Assume $X = 0.05 D = 0.00832 \text{ ft}$

VI = VII' in the previous trial

$$= 0.41 \text{ fpm}$$

$$VII = 1.872 \times 0.0013/0.00833 = 0.293 \text{ fpm}$$

$$VI' = 2.592 + (3.18 - 2.59) \times 0.0013/0.00833$$

$$= 2.68 \text{ fpm}$$

$$\begin{aligned} \text{VII}' &= 1.872 + (2.88 - 1.87) \times 0.0013/0.00833 \\ &= 2.027 \text{ fpm} \end{aligned}$$

$$\begin{aligned} \text{Vav} &= (0.41 + 0.30 + 2.027 + 2.69)/4 \\ &= 1.36 \text{ fpm} \end{aligned}$$

$$t = 0.212/1.36 = 0.156 \text{ min}$$

$$X_a = 0.156 \times 0.0742 = 0.0116 \text{ ft}$$

X_a actual >> X assumed

Second trial:

Assume X = 0.0116 ft

$$\text{VI} = 0.41 \text{ fpm}$$

$$\text{VII} = 0.30 \text{ fpm}$$

$$\begin{aligned} \text{VI}' &= 2.592 + (3.188 - 2.592) \times (0.0116 \\ &\quad + 0.0013 - 0.0083)/0.0083 = 2.92 \text{ fpm} \end{aligned}$$

$$\begin{aligned} \text{VII}' &= 1.872 + (2.880 - 1.872) \times (0.0116 \\ &\quad + 0.0013 - 0.0083)/0.0083 = 2.43 \text{ fpm} \end{aligned}$$

$$\begin{aligned} \text{Vav} &= (0.41 + 0.30 + 2.92 + 2.43)/4 \\ &= 1.51 \text{ fpm} \end{aligned}$$

$$t = 0.213/1.51 = 0.14 \text{ min}$$

$$X_a = 0.14 \times 0.0742 = 0.0104 \text{ ft}$$

$$\therefore \text{Accuracy} = (0.0116 - 0.0104) \times 100/0.0116 = 10\%$$

Since the model requires a 95 percent confidence level ($\pm 5\%$), these results are insufficient; a third trial is required.

Third trial:

Assume X = 0.0104 ft

$$\text{VI} = 0.41 \text{ fpm}$$

$$VII = 0.30 \text{ fpm}$$

$$VI' = 2.592 + (3.188 - 2.592) \times (0.0104 + 0.0013 - 0.0083)/0.0083 = 2.83 \text{ fpm}$$

$$VII' = 1.872 + (2.880 - 1.872) \times (0.0104 + 0.0013 - 0.0083)/0.0083 = 2.28 \text{ fpm}$$

$$V_{av} = (0.41 + 0.30 + 2.83 + 2.28)/4 = 1.43 \text{ fpm}$$

$$t = 0.213/1.43 = 0.146 \text{ min}$$

$$X_a = 0.146 \times 0.0742 = 0.0108 \text{ ft}$$

$$\text{Accuracy} = (0.0104 - 0.0108) \times 100/0.0104 = 4\% < 5\%$$

Therefore, we may confidently state that after a specified time (0.0175 + 0.14, 0.1575 min) and at a specified distance from the entrance (0.027 + 0.213 = 0.24 ft) the particle will settle to a specific depth (equal to 0.0013 + 0.0104 = 0.0134 ft).

The same calculation was repeated until the particle reached the bottom of the tube. The required length was found to be 8.67 ft, and the detention time to be 2.25 min.